

Digital Storage Oscilloscope

GDS-912/GDS-912G

USER MANUAL



ISO-9001 CERTIFIED MANUFACTURER

GW INSTEK

This manual contains proprietary information, which is protected by copyright. All rights are reserved. No part of this manual may be photocopied, reproduced or translated to another language without prior written consent of Good Will company.

The information in this manual was correct at the time of printing. However, Good Will continues to improve products and reserves the rights to change specification, equipment, and maintenance procedures at any time without notice.

Good Will Instrument Co., Ltd.
No. 7-1, Jhongsing Rd., Tucheng Dist., New Taipei City 236, Taiwan.

Table of Contents

| | |
|--|-----------|
| SAFETY INSTRUCTIONS | 5 |
| GETTING STARTED | 9 |
| Front Panel..... | 10 |
| Rear Panel..... | 12 |
| Control Area..... | 13 |
| User Interface Introduction..... | 15 |
| How to Implement the General Inspection | 19 |
| How to Implement the Function Inspection..... | 20 |
| To set the Probe Attenuation Coefficient | 23 |
| How to Use the Probe Safely..... | 24 |
| How to Implement Self-calibration | 25 |
| Introduction to the Vertical System..... | 26 |
| Introduction to the Horizontal System..... | 28 |
| Introduction to the Trigger System..... | 29 |
| ADVANCED USER GUIDEBOOK | 30 |
| To set the Vertical System | 32 |
| Use Mathematical Manipulation Function | 36 |
| Use Vertical Position and Scale Knobs | 42 |
| Set the Horizontal System | 43 |
| Zoom the Waveform..... | 44 |
| To Set the Trigger System..... | 44 |
| To operate the Function Menu | 48 |
| Set the Sampling/Display..... | 49 |
| To Save and Recall a Waveform | 51 |
| To Implement the Auxiliary System Function Setting | 57 |
| To Update your Instrument Firmware..... | 61 |

| | |
|--|-----------|
| To Measure Automatically..... | 63 |
| To Measure with Cursors | 69 |
| To Use Executive Buttons..... | 74 |
| USE THE WAVEFORM GENERATOR (FOR GDS-912G) | 77 |
| Connect the output | 78 |
| Set the waveform | 78 |
| Configure | 83 |
| DEMONSTRATION | 84 |
| Example 1: Measurement a Simple Signal | 84 |
| Example 2: Gain of a Amplifier in a Metering Circuit..... | 86 |
| Example 3: Capturing a Single Signal..... | 88 |
| Example 4: Analyze the Details of a Signal..... | 90 |
| Example 5: Application of X-Y Function | 92 |
| Example 6: Video Signal Trigger..... | 94 |
| TROUBLESHOOTING | 95 |
| SPECIFICATIONS..... | 97 |

S SAFETY INSTRUCTIONS

This chapter contains important safety instructions that you must follow during operation and storage. Read the following before any operation to insure your safety and to keep the instrument in the best possible condition.

Safety Symbols

These safety symbols may appear in this manual or on the Product name.



WARNING

Warning: Identifies conditions or practices that could result in injury or loss of life.



CAUTION

Caution: Identifies conditions or practices that could result in damage to the equipment or to other properties.



DANGER High Voltage



(Note)

Attention required. Refer to the Manual



Protective Conductor Terminal



Earth (ground) Terminal



Do not dispose electronic equipment as unsorted municipal waste. Please use a separate collection facility or contact the supplier from which this instrument was purchased.

Safety Guidelines

General Guideline • Make sure the BNC input voltage does not exceed 300 Vrms.



WARNING



CAUTION

- Never connect a hazardous live voltage to the ground side of the BNC connectors. It might lead to fire and electric shock.
- Do not place any heavy object on the GDS-912 series.
- Avoid severe impact or rough handling that leads to damaging the GDS-912 series.
- Do not discharge static electricity to the GDS-912 series.
- Use only mating connectors, not bare wires, for the terminals.
- Do not block the cooling fan opening.
- Do not perform measurement at a power source or building installation (Note below).
- Do not disassemble the GDS-912 series unless you are qualified.



Note

(Measurement categories) EN 61010-1:2010 specifies the measurement categories and their requirements as follows. The GDS-912 series falls under category I.

- Measurement category IV is for measurements performed at the source of low-voltage installation.
 - Measurement category III is for measurements performed in the building installation.
 - Measurement category II is for measurements performed on circuits directly connected to the low voltage installation.
 - Measurement category I is for measurement performed on circuits not directly connected to Mains.
-

Power Supply**WARNING**

- AC Input voltage: 100 VAC to 240 VAC, 50 Hz to 60 Hz, auto selection. Power consumption: 10 W for GDS-912 series.
 - Connect the protective grounding conductor of the AC power cord to an earth ground, to avoid electrical shock.
-

Cleaning the GDS-912 Series

- Disconnect the power cord before cleaning.
 - Use a soft cloth dampened in a solution of mild detergent and water. Do not spray any liquid.
 - Do not use chemicals containing harsh materials such as benzene, toluene, xylene and acetone.
-

Operation Environment

- Location: Indoor, no direct sunlight, dust free, almost non-conductive pollution (Note below)
- Relative Humidity: $\leq 90\%$ (non-condensing)
- Altitude: < 2000 m
- Temperature: $0\text{ }^{\circ}\text{C}$ to $40\text{ }^{\circ}\text{C}$

**Note**

(Pollution Degree) EN 61010-1:2010 specifies the pollution degrees and their requirements as follows. The GDS-912 series falls under degree 2.

Pollution refers to “addition of foreign matter, solid, liquid, or gaseous (ionized gases), that may produce a reduction of dielectric strength or surface resistivity”.

- Pollution degree 1: No pollution or only dry, non-conductive pollution occurs. The pollution has no influence.
 - Pollution degree 2: Normally only non-conductive pollution occurs. Occasionally, however, a temporary conductivity caused by condensation must be expected.
 - Pollution degree 3: Conductive pollution occurs, or dry, non-conductive pollution occurs which becomes conductive due to condensation which is expected. In such conditions, equipment is normally protected against exposure to direct sunlight, precipitation, and full wind pressure, but neither temperature nor humidity is controlled.
-

Storage environment

- Location: Indoor
 - Temperature: $-10\text{ }^{\circ}\text{C}$ to $70\text{ }^{\circ}\text{C}$
 - Humidity: Up to 80% RH (non-condensing)
-

Disposal

Do not dispose this instrument as unsorted municipal waste. Please use a separate collection facility or contact the supplier from which this instrument was purchased. Please make sure discarded electrical waste is properly recycled to reduce environmental impact.

G E T T I N G S T A R T E D

This chapter makes a simple description of the operation and function of the front panel of the oscilloscope, enabling you to be familiar with the use of the oscilloscope in the shortest time.

| | |
|--|----|
| Front Panel..... | 10 |
| GDS-912G | 10 |
| GDS-912 | 10 |
| Rear Panel | 12 |
| Control Area | 13 |
| User Interface Introduction | 15 |
| How to Implement the General Inspection | 19 |
| How to Implement the Function Inspection | 20 |
| How to Set the Probe Attenuation Coefficient | 21 |
| To set the Probe Attenuation Coefficient..... | 23 |
| How to Use the Probe Safely | 24 |
| How to Implement Self-calibration | 25 |
| Introduction to the Vertical System | 26 |
| Introduction to the Horizontal System | 28 |
| Introduction to the Trigger System..... | 29 |

Front Panel

The front panel has knobs and function buttons. The 5 buttons in the column on the right side of the display screen are menu selection buttons, through which, you can set the different options for the current menu. The other buttons are function buttons, through which, you can enter different function menus or obtain a specific function application directly.

GDS-912G

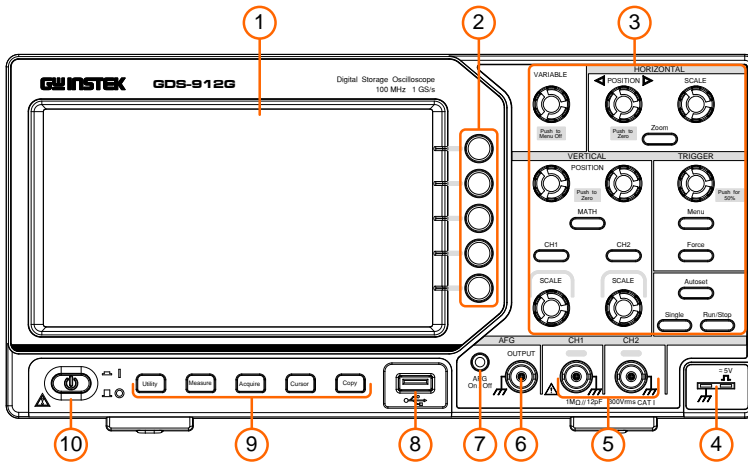

GDS-912

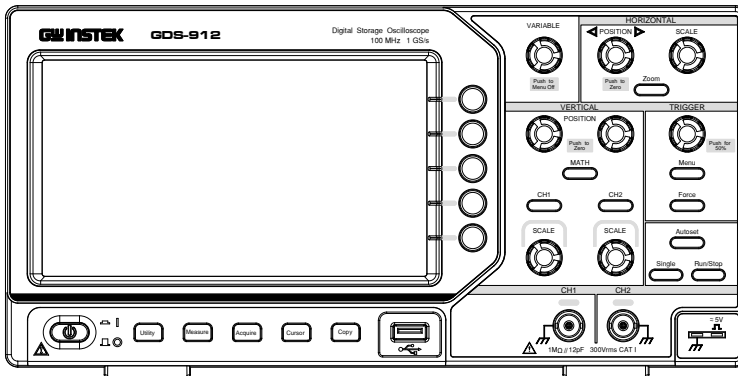

1. Display area
2. Menu selection buttons Select the right menu item
3. Button and knob control area
4. Probe Compensation Measurement signal (5 V/ 1 kHz) output.
5. Oscilloscope signal input channel
6. Signal input channel (for GDS-912G)
7. Signal menu button (for GDS-912G)
8. USB Host port It is used to transfer data when external USB equipment connects to the oscilloscope regarded as "host device". For example: Saving the waveform to USB flash disk needs to use this port.
9. Function menu button
10. Power on/off

Rear Panel

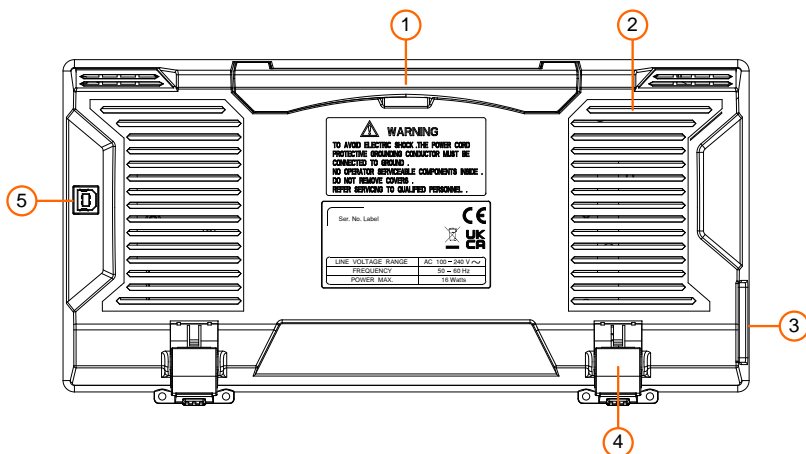

1. Handle
2. Air vents
3. AC power input jack
4. Foot stool Adjust the tilt angle of the oscilloscope
5. USB Device port It is used to transfer data when external USB equipment connects to the oscilloscope regarded as "slave device". For example: to use this port when connect PC to the oscilloscope by USB.

Control Area

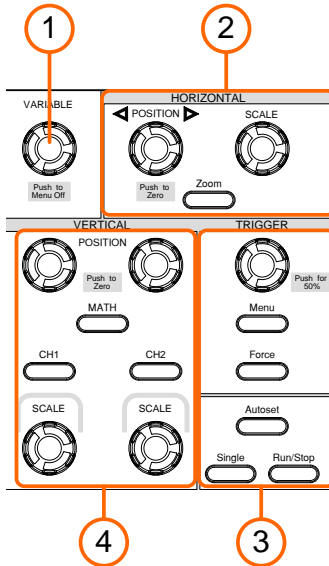

- 1. VARIABLE Knob** When a **M** symbol appears in the menu, it indicates you can turn the VARIABLE Knob to select the menu or set the value. You can push it to close the menu on the left and right.
- 2. Horizontal control area** With 1 button and 2 knobs. "Zoom" button refer to horizontal system setting menu, "Horizontal Position" knob control trigger position, "Horizontal Scale" control time base.

3. Trigger control area
With 5 buttons and 1 knob. The Trigger Level knob is to adjust trigger voltage. "Menu" and "Force" buttons refer to trigger system setting. The "Single" Press this function key to directly set the trigger mode to single, that is, when a trigger is detected, sample a waveform and then stop. "Run/stop" runs and stops waveform sampling

4. Vertical control area
With 3 buttons and 4 knobs. In the stopped state, the waveform vertical gear and horizontal time base can be adjusted within a certain range, which is equivalent to extending the signal in the horizontal or vertical direction. When the horizontal time base is 50 ms or less, the horizontal time base can be extended down by 4 stalls.

"CH1" and "CH2" correspond to setting menu in CH1 and CH2, "Math" button refer to math menu, the math menu consists of six kinds of operations, including CH1-CH2, CH2-CH1, CH1+CH2, CH1*CH2, CH1/CH2 and FFT. Two "Vertical Position" knob control the vertical position of CH1/CH2, and two "Scale" knob control voltage scale of CH1, CH2.

User Interface Introduction

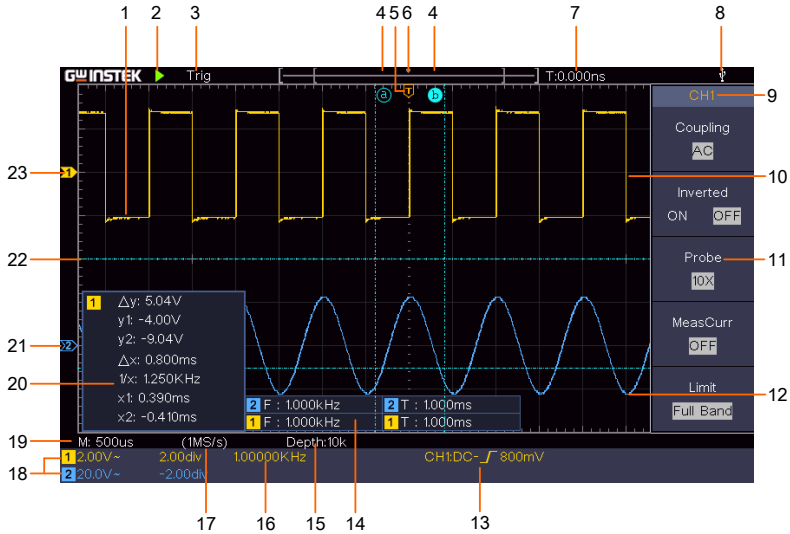

1. Waveform Display Area
2. Run/Stop
3. The state of trigger, including
 - Auto: Automatic mode and acquire waveform without triggering
 - Trig: Trigger detected and acquire waveform.
 - Ready: Pre-triggered data captured and ready for a trigger.
 - Scan: Capture and display the waveform continuously.
 - Stop: Data acquisition stopped.
4. The two blue dotted lines indicates the vertical position of cursor measurement.
5. The T pointer indicates the horizontal position for the trigger.
6. The pointer indicates the trigger position in the record length.

- 7. It shows present triggering value and displays the site of present window in internal memory.
- 8. It indicates that there is a USB disk connecting with the oscilloscope.
- 9. Channel identifier of current menu.
- 10. The waveform of CH1.
- 11. Right Menu
- 12. The waveform of CH2

13. Current trigger type

 Rising edge triggering

 Falling edge triggering

 Video line synchronous triggering

 Video field synchronous triggering

The reading shows the trigger level value of the corresponding channel.

14. It indicates the measured type and value of the corresponding channel.

“T” means period

“F” means frequency

“V” means the average value

“Vp” the peak-peak value

“Vr” the root-mean-square value

“Ma” the maximum amplitude value

“Mi” the minimum amplitude value

“Vt” the Voltage value of the waveform’s flat top value

“Vb” the Voltage value of the waveform’s flat base

“Va” the amplitude value

“Os” the overshoot value

“Ps” the Preshoot value

“RT” the rise time value

“FT” the fall time value

“PW” the +width value

“NW” the -Width value

"+D" the +Duty value
 "-D" the -Duty value
 "PD" the Delay A->B ⏏ value
 "ND" the Delay A->B ⏏ value
 "TR" the Cycle RMS
 "CR" the Cursor RMS
 "WF" the Screen Duty
 "RP" the Phase
 "+PC" the +Pulse count
 "-PC" the - Pulse count
 "+E" the Rise edge count
 "-E" the Fall edge count
 "AR" the Area
 "CA" the Cycle area.

15. The readings show the record length
16. The frequency of the trigger signal.
17. The readings show current sample rate.
18. The readings indicate the corresponding Voltage Division and the Zero Point positions of the channels.

| |
|---|
| BW indicates bandwidth limit. |
| The icon shows the coupling mode of the channel. |
| "—" indicates direct current coupling |
| "~" indicates AC coupling |
| " $\frac{\perp}{\equiv}$ " indicates GND coupling |
19. The reading shows the setting of main time base.
20. It is cursor measure window, showing the absolute values and the readings of the cursors.
21. The blue pointer shows the grounding datum point (zero point position) of the waveform of the CH2 channel. If the pointer is not displayed, it means that this channel is not opened.
22. The two blue dotted lines indicate the horizontal position of cursor measurement.

23. The yellow pointer indicates the grounding datum point (zero point position) of the waveform of the CH1 channel. If the pointer is not displayed, it means that the channel is not opened.

How to Implement the General Inspection

After you get a new oscilloscope, it is recommended that you should make a check on the instrument according to the following steps:

Steps

1. Check whether there is any damage caused by transportation.
If it is found that the packaging carton or the foamed plastic protection cushion has suffered serious damage, do not throw it away first till the complete device and its accessories succeed in the electrical and mechanical property tests.
2. Check the Accessories
You can check whether there is any loss of accessories with reference to this description. If it is found that there is any accessory lost or damaged, please get in touch with the distributor of our responsible for this service or the our local offices.
3. Check the Complete Instrument
If it is found that there is damage to the appearance of the instrument, or the instrument can not work normally, or fails in the performance test, please get in touch with the our distributor responsible for this business or the our local offices. If there is damage to the instrument caused by the transportation, please keep the package. With the transportation department or our distributor responsible for this business informed about it, a repairing or replacement of the instrument will be arranged by the us.

How to Implement the Function Inspection

Make a fast function check to verify the normal operation of the instrument, according to the following steps:

- Steps
1. Connect the power cord to a power source.
Press the  button on the bottom left of the instrument. The instrument carries out all self-check items and shows the Boot Logo. Push the Utility button, select Function in the right menu. Select Adjust in the left menu, select Default in the right menu. The default attenuation coefficient set value of the probe in the menu is 10 X.
 2. Set the Switch in the Oscilloscope Probe as 10 X and Connect the Oscilloscope with CH1 Channel. Align the slot in the probe with the plug in the CH1 connector BNC, and then tighten the probe with rotating it to the right side.

Connect the probe tip and the ground clamp to the connector of the probe compensator.

3. Push the Autoset Button on the front panel. The square wave of 1 kHz frequency and 5 V peak-peak value will be displayed in several seconds (see figure below)

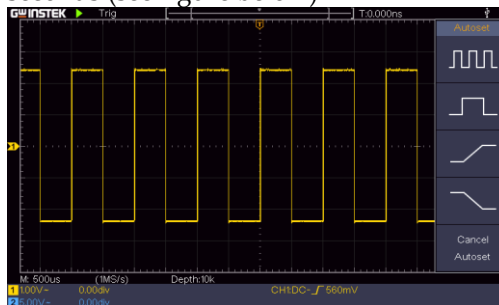

Check CH2 by repeating Step 2 and Step 3.

How to Set the Probe Attenuation Coefficient

When connect the probe with any input channel for the first time, make this adjustment to match the probe with the input channel. The probe which is not compensated or presents a compensation deviation will result in the measuring error or mistake. For adjusting the probe compensation, please carry out the following steps:

- Steps
1. Set the attenuation coefficient of the probe in the menu as 10 X and that of the switch in the probe as 10 X (see the setion "How to Set the Probe Attenuation Coefficient" on page 21), and connect the probe with the CH1 channel. If a probe hook tip is used, ensure that it keeps in close touch with the probe. Connect the probe tip with the signal connector of the probe compensator and connect the reference wire clamp with the ground wire connector of the probe connector, and then push the Autoset button on the front panel.
 2. Check the displayed waveforms and regulate the probe till a correct compensation is achieved (see figures below)

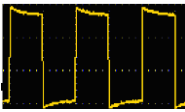
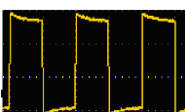
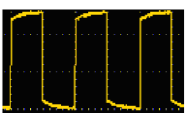
| | | |
|---|---|-----------------------|
| Displayed Waveforms of the Probe Compensation |  | Overcompensated |
| |  | Compensated correctly |
| |  | Under compensated |



For more details about probe inspection and probe compensation, please refer to page 59.

Adjust Probe

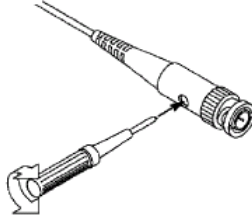

3. Repeat the steps mentioned if needed.

To set the Probe Attenuation Coefficient

The probe has several attenuation coefficients, which will influence the vertical scale factor of the oscilloscope.

To change or check the probe attenuation coefficient in the menu of oscilloscope:

- | | |
|-------|--|
| Steps | <ol style="list-style-type: none">1. Push the function menu button of the used channels (CH1 or CH2 button).2. Select Probe in the right menu; turn the VARIABLE Knob to select the proper value in the left menu corresponding to the probe. |
|-------|--|
-



Caution

The default attenuation coefficient of the probe on the instrument is preset to 10 X. Make sure that the set value of the attenuation switch in the probe is the same as the menu selection of the probe attenuation coefficient in the oscilloscope.

The set values of the probe switch are 1 X and 10 X (See the figure below)

Attenuation
Switch

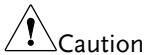
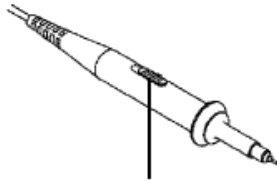

Caution

When the attenuation switch is set to 1 X, the probe will limit the bandwidth of the oscilloscope in 5 MHz. To use the full bandwidth of the oscilloscope, the switch must be set to 10 X.

How to Use the Probe Safely

The safety guard ring around the probe body protects your finger against any electric shock, shown as figure below.

Finger Guard

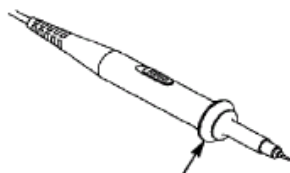

Warning

To avoid electric shock, always keep your finger behind the safety guard ring of the probe during the operation.

To protect you from suffering from the electric shock, do not touch any metal part of the probe tip when it is connected to the power supply.

Before making any measurements, always connect the probe to the instrument and connect the ground terminal to the earth.

How to Implement Self-calibration

The self-calibration application can make the oscilloscope reach the optimum condition rapidly to obtain the most accurate measurement value. You can carry out this application program at any time. This program must be executed whenever the change of ambient temperature is 5 °C or over.

Before performing a self-calibration, disconnect all probes or wires from the input connector. Push the Utility button, select Function in the right menu, select "Adjust" in the left menu, and then select "Self Cal" in the right menu; run the program after everything is ready.

Introduction to the Vertical System

As shown in the figure below, here are a few of buttons and knobs in Vertical Controls. The following practices will gradually direct you to be familiar with the using of the vertical setting.

Vertical Control
Zone

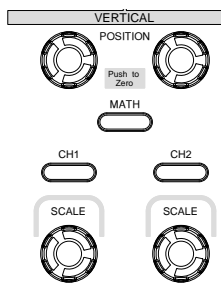

Steps

1. Use the Vertical Position knob to show the signal in the center of the waveform window. The Vertical Position knob functions the regulating of the vertical display position of the signal. Thus, when the Vertical Position knob is rotated, the pointer of the earth datum point of the channel is directed to move up and down following the waveform.
 - **Measuring Skill**
If the channel is under the DC coupling mode, you can rapidly measure the DC component of the signal through the observation of the difference between the wave form and the signal ground.
If the channel is under the AC mode, the DC component would be filtered out. This mode helps you display the AC component of the signal with a higher sensitivity.
 - **Vertical offset back to 0 shortcut key**
Turn the Vertical Position knob to change the vertical display position of channel and push the position knob to set the vertical

display position back to 0 as a shortcut key, this is especially helpful when the trace position is far out of the screen and want it to get back to the screen center immediately.

2. Change the Vertical Setting and Observe the Consequent State Information Change.

With the information displayed in the status bar at the bottom of the waveform window, you can determine any changes in the channel vertical scale factor.

- Turn the Vertical Scale knob and change the “Vertical Scale Factor (Voltage Division)”, it can be found that the scale factor of the channel corresponding to the status bar has been changed accordingly.
 - Push buttons of CH1, CH2 and Math, the operation menu, symbols, waveforms and scale factor status information of the corresponding channel will be displayed in the screen.
-

Introduction to the Horizontal System

As shown in the figure below, there are a button and two knobs in the Horizontal Controls. The following practices will gradually direct you to be familiar with the setting of horizontal time base.

Horizontal
Control Zone

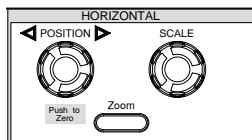

Steps

1. Turn the Horizontal Scale knob to change the horizontal time base setting and observe the consequent status information change. Turn the Horizontal Scale knob to change the horizontal time base, and it can be found that the Horizontal Time Base display in the status bar changes accordingly.
2. Use the Horizontal Position knob to adjust the horizontal position of the signal in the waveform window. The Horizontal Position knob is used to control the triggering displacement of the signal or for other special applications. If it is applied to triggering the displacement, it can be observed that the waveform moves horizontally with the knob when you rotate the Horizontal Position knob.

Triggering displacement back to 0 shortcut key

Turn the Horizontal Position knob to change the horizontal position of channel and push the Horizontal Position knob to set the triggering displacement back to 0 as a shortcut key.

3. Push the Horizontal Zoom button to switch between the normal mode and the wave zoom mode.

Introduction to the Trigger System

As shown in the figure below, there are one knob and two buttons make up Trigger Controls. The following practices will direct you to be familiar with the setting of the trigger system gradually.

Trigger Control
Zone

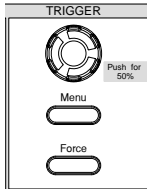

Steps

1. Push the Trigger Menu button and call out the trigger menu. With the operations of the menu selection buttons, the trigger setting can be changed.
2. Use the Trigger Level knob to change the trigger level setting. By turning the Trigger Level knob, the trigger indicator in the screen will move up and down. With the movement of the trigger indicator, it can be observed that the trigger level value displayed in the screen changes accordingly.
3. Push the Force button to force a trigger signal, which is mainly applied to the “Normal” and “Single” trigger modes.



Turning the Trigger Level knob can change trigger level value and it is also the hotkey to set trigger level as the vertical mid point values of the amplitude of the trigger signal.

ADVANCED USER

GUIDEBOOK

| | |
|---|----|
| To set the Vertical System | 32 |
| Setting of CH1 and CH2 | 32 |
| To turn waveforms on or off (channel, math) | 32 |
| Use Mathematical Manipulation Function | 36 |
| The Waveform Calculation | 36 |
| Using FFT function | 37 |
| To select the FFT window | 39 |
| Notes for using FFT | 40 |
| Use Vertical Position and Scale Knobs | 42 |
| Set the Horizontal System | 43 |
| Zoom the Waveform | 44 |
| To Set the Trigger System..... | 44 |
| Trigger Control | 45 |
| Single Trigger | 45 |
| Edge Trigger | 45 |
| Video Trigger..... | 47 |
| Alternate Trigger..... | 48 |
| To operate the Function Menu | 48 |
| Set the Sampling/Display | 49 |
| Persist | 50 |
| XY Format..... | 50 |
| Counter | 51 |
| To Save and Recall a Waveform..... | 51 |
| Save and Recall the Waveform | 53 |
| Shortcut for Save function | 54 |
| Save the current screen image | 54 |
| USB disk Requirements | 54 |

| | |
|---|----|
| Use system-provided function to format the USB disk | 55 |
| To Implement the Auxiliary System Function | |
| Setting | 57 |
| Configure | 57 |
| Display | 57 |
| Adjust..... | 58 |
| Do Self Cal (Self-Calibration) | 58 |
| Probe checking | 59 |
| Save | 60 |
| Update | 60 |
| To Update your Instrument Firmware..... | 61 |
| USB memory device requirements | 61 |
| To Measure Automatically | 63 |
| Measure | 64 |
| The automatic measurement of voltage parameters | 65 |
| The automatic measurement of time parameters ... | 66 |
| Other measurements..... | 67 |
| To Measure with Cursors | 69 |
| The Cursor Measurement for normal mode | 69 |
| Auto Cursor..... | 71 |
| The Cursor Measurement for FFT mode | 72 |
| To Use Executive Buttons | 74 |
| [Autoset] button | 74 |
| Judge waveform type by Autoset | 74 |
| Description of the right menu options..... | 75 |
| [Run/Stop] button | 76 |
| [Copy] button..... | 76 |

To set the Vertical System

The VERTICAL CONTROLS includes three menu buttons such as CH1, CH2 and Math, and four knobs such as Vertical Position, Vertical Scale for each channel.

Setting of CH1 and CH2

Each channel has an independent vertical menu and each item is set respectively based on the channel.

To turn waveforms on or off (channel, math)

Pushing the CH1, CH2, or Math buttons have the following effect:

- If the waveform is off, the waveform is turned on and its menu is displayed.
- If the waveform is on and its menu is not displayed, its menu will be displayed.
- If the waveform is on and its menu is displayed, the waveform is turned off and its menu goes away.

The description of the Channel Menu is shown as the following list:

| Function Menu | Setting | Description |
|---------------|--------------------------------|---|
| Coupling | DC | Pass both AC and DC components of the input signal. |
| | AC | Block the DC component of the input signal. |
| | Ground | Disconnect the input signal. |
| Inverted | ON | Display inverted waveform. |
| | OFF | Display original waveform. |
| Probe | 1 X 10 X 100 X 1000 X | Match this to the probe attenuation factor to have an accurate reading of vertical scale. |

| | | |
|----------|--------------------|---|
| MeasCurr | OFF V/A mV/A | If you are measuring current by probing the voltage drop across a resistor, choose V/A mV/A. Turn the VARIABLE Knob to set the Amps/Volts ratio. The range is 100 mA/V to 1 kA/V. Amps/Volts ratio = 1/Resistor value Volts/Amp ratio is automatically calculated. |
| Limit | OFF 20 M | Close the limit of bandwidth. Limit the channel bandwidth to 20 MHz to reduce display noise. |

To set channel coupling

Taking the Channel 1 for example, the measured signal is a square wave signal containing the direct current bias. The operation steps are shown as below:

1. Push the CH1 button to show the CH1 SETUP menu.
2. In the right menu, select **Coupling** as **DC**. Both DC and AC components of the signal are passed.
3. In the right menu, select **Coupling** as **AC**. The direct current component of the signal is blocked.

To invert a waveform

Waveform inverted: the displayed signal is turned 180 degrees against the phase of the earth potential.

Taking the Channel 1 for example, the operation steps are shown as follows:

4. Push the CH1 button to show the CH1 SETUP menu.
5. In the right menu, select **Inverted** as **ON**, the waveform is inverted. Push again to switch to **OFF**, the waveform goes back to its original one.

| | |
|--|---|
| To adjust the probe attenuation | <p>For correct measurements, the attenuation coefficient settings in the operating menu of the Channel should always match what is on the probe (see “How to Set the Probe Attenuation Coefficient” on P21). If the attenuation coefficient of the probe is 1:1, the menu setting of the input channel should be set to 1 X.</p> <p>Take the Channel 1 as an example, the attenuation coefficient of the probe is 10:1, the operation steps are shown as follows:</p> <ol style="list-style-type: none">1. Push the CH1 button to show the CH1 SETUP menu.2. In the right menu, select Probe. In the left menu, turn the VARIABLE Knob to set it as 10 X. |
| To measure current by probing the voltage drop across a resistor | <p>Take the Channel 1 as an example, if you are measuring current by probing the voltage drop across a 1 Ω resistor, the operation steps are shown as follows:</p> <ol style="list-style-type: none">1. Push the CH1 button to show CH1 SETUP menu.2. In the right menu, set MeasCurr as V/A mV/A, the A/V radio menu will appear below. Select it; turn the VARIABLE Knob to set the Amps/Volts ratio. Amps/Volts ratio = 1/Resistor value. Here the A/V radio should be set to 1. |
| To set the bandwidth | <p>Take the Channel 1 as an example, the operation steps are shown as follows:</p> <ol style="list-style-type: none">1. Push the CH1 button to show the CH1 SETUP menu.2. In the lower menu, select Limit.3. In the right menu, select OFF. The high-frequency components contained in the measured signal can pass through. |

4. In the right menu, select **20 M**. The bandwidth is limited to 20 M, and the high-frequency components of the measured signal containing more than 20 MHz are blocked.
-

Use Mathematical Manipulation Function

The Mathematical Manipulation function is used to show the results of the addition, multiplication, division and subtraction operations between two channels, or the FFT operation for a channel. Press the Math button to display the menu on the right.

The Waveform Calculation

Press the **Math** button to display the menu on the right, select **Type** as **Math**.

| Function Menu | Setting | Description |
|------------------|------------|--|
| Type | Math | Display the Math menu. |
| Factor1 | CH1 CH2 | Select the signal source of the factor1. |
| Sign | + - * / | Select the sign of mathematical manipulation. |
| Factor2 | CH1 CH2 | Select the signal source of the factor2. |
| Next Page | | Enter next page. |
| Vertical (div) | | Turn the VARIABLE Knob to adjust the vertical position of the Math waveform. |
| Vertical (V/div) | | Turn the VARIABLE Knob to adjust the voltage division of the Math waveform. |
| Prev Page | | Enter previous page. |

Taking the additive operation between Channel 1 and Channels 2 for example, the operation steps are as follows:

- | | |
|-------|---|
| Steps | <ol style="list-style-type: none"> 1. Press the Math button to display the math menu in the right. The pink M waveform appears on the screen. 2. In the right menu, select Type as Math. 3. In the right menu, select Factor1 as CH1. 4. In the right menu, select Sign as +. 5. In the right menu, select Factor2 as CH2. |
|-------|---|

6. Press **Next Page** in the right menu. Select **Vertical (div)**, the **M** symbol is in front of **div**, turn the VARIABLE Knob to adjust the vertical position of Math waveform.
7. Select **Vertical (V/div)** in the right menu, the **M** symbol is in front of the voltage, turn the VARIABLE Knob to adjust the voltage division of Math waveform.

Using FFT function

The FFT (fast Fourier transform) math function mathematically converts a time-domain waveform into its frequency components. It is very useful for analyzing the input signal on Oscilloscope. You can match these frequencies with known system frequencies, such as system clocks, oscillators, or power supplies.

FFT function in this oscilloscope transforms 2048 data points of the time-domain signal into its frequency components mathematically (the record length should be 10 K or above). The final frequency contains 1024 points ranging from 0 Hz to Nyquist frequency.

Press the Math button to display the menu on the right, select Type as FFT.

| Function Menu | Setting | Description |
|---------------|---|--|
| Type | FFT | Display the FFT menu. |
| Source | CH1 CH2 | Select CH1 as FFT source. Select CH2 as FFT source. |
| Window | Hamming Rectangle Blackman Hanning Bartlett Kaiser | Select window for FFT. |
| Format | Vrms dB | Select Vrms for Format. Select dB for Format. |
| Next Page | | Enter next page. |

| | | |
|-----------|-------------------------|--|
| Hori (Hz) | Frequency frequency/div | Switch to select the horizontal position or time base of the FFT waveform, turn the VARIABLE Knob to adjust it. |
| Vertical | div V or dBVrms | Switch to select the vertical position or voltage division of the FFT waveform, turn the VARIABLE Knob to adjust it. |
| Prev Page | | Enter previous page. |





Taking the FFT operation for example, the operation steps are as follows:

-
- Steps
1. Press the **Math** button to display the math menu in the right.
 2. In the right menu, select Type as **FFT**.
 3. In the right menu, select Source as **CH1**.
 4. In the right menu, select Window. Select the proper window type in the left menu.
 5. In the right menu, select Format as **Vrms** or **dB**.
 6. In the right menu, press **Hori (Hz)** to make the **M** symbol in front of the frequency value, turn the VARIABLE Knob to adjust the horizontal position of FFT waveform; then press to make the **M** symbol in front of the **frequency/div** below, turn the VARIABLE Knob to adjust the time base of FFT waveform.
 7. Select Vertical in the right menu; do the same operations as above to set the vertical position and voltage division.
-

To select the FFT window

There are 6 FFT windows. Each one has trade-offs between frequency resolution and magnitude accuracy. What you want to measure and your source signal characteristics help you to determine which window to use. Use the following guidelines to select the best window.

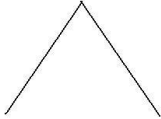
| Type | Characteristics | Window |
|-----------|--|---|
| Hamming | <p>Better solution for magnitude than Rectangle, and good for frequency as well. It has slightly better frequency resolution than Hanning.</p> <p>Recommend to use for:</p> <ul style="list-style-type: none"> • Sine, periodic and narrow band random noise. • Transients or bursts where the signal levels before and after the event are significantly different. |  |
| Rectangle | <p>Best solution for frequency, worst for magnitude.</p> <p>Best type for measuring the frequency spectrum of nonrepetitive signals and measuring frequency components near DC.</p> <p>Recommend to use for:</p> <ul style="list-style-type: none"> • Transients or bursts, the signal level before and after the event are nearly equal. • Equal-amplitude sine waves with frequencies those are very close. • Broadband random noise with a relatively slow varying spectrum. |  |

| | | |
|-----------------|---|--|
| <p>Blackman</p> | <p>Best solution for magnitude, worst for frequency.</p> <p>Recommend to use for:</p> <ul style="list-style-type: none"> • Single frequency waveforms, to find higher order harmonics. |  |
| <p>Hanning</p> | <p>Good for magnitude, but poorer frequency resolution than Hamming.</p> <p>Recommend to use for:</p> <ul style="list-style-type: none"> • Sine, periodic and narrow band random noise. • Transients or bursts where the signal levels before and after the event are significantly different. |  |
| <p>Bartlett</p> | <p>Very similar to a triangular window (with zero values at both ends).</p> |  |
| <p>Kaiser</p> | <p>When using the Kaiser window, the frequency resolution is moderate, while spectral leakage and amplitude accuracy are both good. The Kaiser window is best suited when the frequencies are very close but the amplitudes differ significantly (its sidelobe level and shape factor are most similar to the traditional Gaussian RBW). This window is also very well-suited for random signals.</p> |  |

Notes for using FFT

- Use the default **dB** scale for details of multiple frequencies, even if they have very different amplitudes. Use the **Vrms** scale to compare frequencies.

- DC component or offset can cause incorrect magnitude values of FFT waveform. To minimize the DC component, choose AC Coupling on the source signal.
 - To reduce random noise and aliased components in repetitive or single-shot events, set the oscilloscope acquisition mode to average.
-

Nyquist frequency The Nyquist frequency is the highest frequency that any real-time digitizing oscilloscope can acquire without aliasing. This frequency is half of the sample rate. Frequencies above the Nyquist frequency will be under sampled, which causes aliasing. So pay more attention to the relation between the frequency being sampled and measured.

Use Vertical Position and Scale Knobs

Application

- The Vertical Position knob is used to adjust the vertical positions of the waveforms. The analytic resolution of this control knob changes with the vertical division.
- The Vertical Scale knob is used to regulate the vertical resolution of the wave forms. The sensitivity of the vertical division steps as 1-2-5. The vertical position and vertical resolution is displayed at the left bottom corner of the screen (see figure below)

Information about Vertical Position

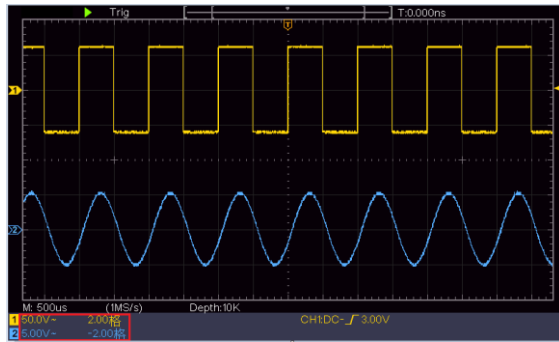

Set the Horizontal System

The HORIZONTAL CONTROLS includes the Horizontal ZOOM button and such knobs as Horizontal Position and Horizontal Scale.

| | |
|--------------------------|--|
| Horizontal Position knob | This knob is used to adjust the horizontal positions of all channels (include those obtained from the mathematical manipulation), the analytic resolution of which changes with the time base. |
| Horizontal Scale knob | It is used to set the horizontal scale factor for setting the main time base or the window. |
| Horizontal Zoom button | Push it to switch between the normal mode and the wave zoom mode. For more detailed operations, see the introductions below. |

Zoom the Waveform

Push the Horizontal Zoom button to enter wave zoom mode. The top half of the display shows the Main window and the bottom half displays the Zoom window. The Zoom window is a magnified portion of the Main window.

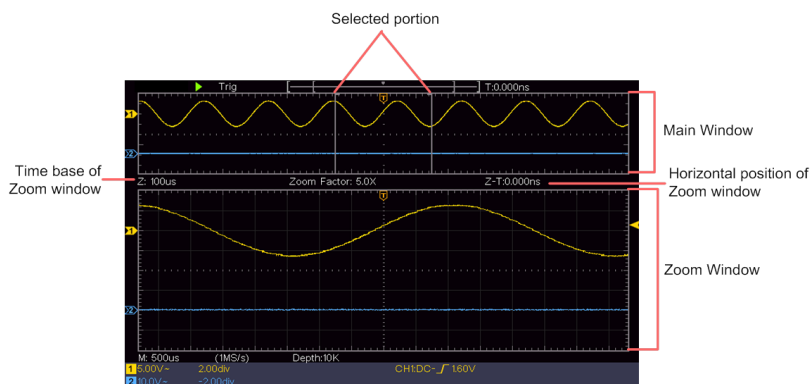

In normal mode, the **Horizontal Position** and **Horizontal Scale** knobs are used to adjust the horizontal position and time base of the Main window.

In wave zoom mode, the **Horizontal Position** and **Horizontal Scale** knobs are used to adjust the horizontal position and time base of the Zoom window.

To Set the Trigger System

Trigger determines when DSO starts to acquire data and display waveform. Once trigger is set correctly, it can convert the unstable display to meaningful waveform.

When DSO starts to acquire data, it will collect enough data to draw waveform on left of trigger point. DSO continues to acquire data while waiting for trigger condition to occur. Once it detects a trigger it will acquire enough data continuously to draw the waveform on right of trigger point.

Trigger control area consists of 1 knob and 2 menu buttons.

| | |
|---------------|---|
| Trigger Level | The knob that set the trigger level; push the knob and the level will be set as the vertical mid point values of the amplitude of the trigger signal. |
| Force | Force to create a trigger signal and the function is mainly used in "Normal" and "Single" mode. |
| Trigger Menu | The button that activates the trigger control menu. |

Trigger Control

The oscilloscope provides two trigger types: single trigger, alternate trigger. Each type of trigger has different sub menus.

| | |
|-------------------|---|
| Single trigger | Use a trigger level to capture stable waveforms in two channels simultaneously. |
| Alternate trigger | Trigger on non-synchronized signals. |

The **Single Trigger**, **Alternate Trigger** menus are described respectively as follows:

Single Trigger

Single trigger has two types: edge trigger, video trigger

| | |
|---------------|---|
| Edge Trigger | It occurs when the trigger input passes through a specified voltage level with the specified slope. |
| Video Trigger | Trigger on fields or lines for standard video signal. |

The two trigger modes in Single Trigger are described respectively as follows:

Edge Trigger

An edge trigger occurs on trigger level value of the specified edge of input signal. Select Edge trigger mode to trigger on rising edge or falling edge.

Push the Trigger Menu button to display the Trigger menu on the right. Select Type as Single in the right menu. Select Single as Edge in the right menu.

In Edge Trigger mode, the trigger setting information is displayed on bottom right of the screen, for example, **CH1:DC- \int 0.00mV** , indicates that trigger type is edge, trigger source is CH1, coupling is DC, and trigger level is 0.00 mV.

Edge menu list:

| Menu | Setting | Description |
|---------------|--|--|
| Type | Single | Set vertical channel trigger type as single trigger. |
| Single | Edge | Set vertical channel single trigger type as edge trigger. |
| Source | CH1 CH2 | Channel 1 as trigger signal. Channel 2 as trigger signal. |
| Mode | Auto Normal Single | Acquire waveform even no trigger occurs Acquire waveform when trigger occurs When trigger occurs, acquire one waveform then stop |
| Next Page | | Enter next page. |
| Coupling | AC DC | Block the direct current component. Allow all component pass. |
| Slope |  | Trigger on rising edge. Trigger on falling edge. |
| Holdoff | | 100 ns to 10 s, turn the VARIABLE Knob to set time interval before another trigger occur. |
| Holdoff Reset | | Set Holdoff time as default value (100 ns). |
| Prev Page | | Enter previous page. |

Trigger Level Trigger level indicates vertical trig position of the channel, rotate trig level knob to move trigger level, during setting, a dotted line displays to show trig position, and the value of trigger level changes at the right corner, after setting, dotted line disappears.

Video Trigger

Choose video trigger to trigger on fields or lines of NTSC, PAL or SECAM standard video signals.

Push the Trigger Menu button to display the Trigger menu on the right. Select Type as Single in the right menu. Select Single as Video in the right menu.

In Video Trigger mode, the trigger setting information is displayed on bottom right of the screen, for example, **CH1 :  ALL** , indicates that trigger type is Video, trigger source is CH1, and Sync type is Even.

Video Trigger menu list:

| Menu | Setting | Description |
|-----------|--|--|
| Type | Single | Set vertical channel trigger type as single trigger. |
| Single | Video | Set vertical channel single trigger type as video trigger. |
| Source | CH1 CH2 | Select CH1 as the trigger source Select CH2 as the trigger source |
| Modu | NTSC PAL SECAM | Select video modulation |
| Next Page | | Enter next page |
| Sync | Line Field Odd Even Line NO. | Synchronic trigger in video line Synchronic trigger in video field Synchronic trigger in video odd filed Synchronic trigger in video even field Synchronic trigger in designed video line. Press Line NO. menu item, turn the VARIABLE Knob to set the line number. |
| Prev Page | | Enter previous page |

Alternate Trigger

Trigger signal comes from two vertical channels when alternate trigger is on. This mode is used to observe two unrelated signals. Trigger mode is edge trigger.

Alternate trigger menu list:

| Menu | Setting | Description |
|---------------|---|---|
| Type | ALT | Set vertical channel trigger type as alternate trigger. |
| Source | CH1 CH2 | Channel 1 as trigger signal. Channel 2 as trigger signal. |
| Next Page | | Enter next page. |
| Coupling | AC DC | Block the direct current component. Allow all component pass. |
| Slope |  | Trigger on rising edge. Trigger on falling edge. |
| Holdoff | | 100 ns to 10 s, turn the VARIABLE Knob to set time interval before another trigger occur. |
| Holdoff Reset | | Set Holdoff time as default value (100 ns). |
| Prev Page | | Enter previous page. |

To operate the Function Menu

The function menu control zone includes 4 function menu buttons: **Utility**, **Measure**, **Acquire**, **Cursor**, and one immediate-execution buttons: **Copy**.

Set the Sampling/Display

Push the Acquire button, the Sampling and Display menu is shown in the right as follows:

| Function Menu | Setting | Description |
|---------------|---|--|
| Acqu Mode | Sample | Normal sampling mode. |
| | Peak Detect | Use to capture maximal and minimal samples. Finding highest and lowest points over adjacent intervals. It is used for the detection of the jamming burr and the possibility of reducing the confusion. |
| | Average | It is used to reduce the random and don't-care noises, with the optional number of averages. Turn the VARIABLE Knob to select 4, 16, 64, 128 in the left menu. |
| Length | 1000 10 K 100 K 1 M 10 M 20 M | Select the length to record. |
| Persist | OFF 1 Second 2 Seconds 5 Seconds Infinity | Set the persistence time. |
| XY Mode | ON OFF | Turn on/off XY display function. |
| Counter | ON OFF | Turn on/off counter. |

Persist

When the Persist function is used, the persistence display effect of the picture tube oscilloscope can be simulated. The reserved original data is displayed in fade color and the new data is in bright color.

- | | |
|-------|--|
| Steps | <ol style="list-style-type: none">1. Push the Acquire button.2. In the right menu, press Persist to select the persist time, including OFF, 1 Second, 2 Seconds, 5 Seconds and Infinity. When the "Infinity" option is set for Persist Time, the measuring points will be stored till the controlling value is changed. Select OFF to turn off persistence and clear the display. |
|-------|--|
-

XY Format

This format is only applicable to Channel 1 and Channel 2. After the XY display format is selected, Channel 1 is displayed in the horizontal axis and Channel 2 in the vertical axis; the oscilloscope is set in the un-triggered sample mode: the data are displayed as bright spots.

The operations of all control knobs are as follows:

- The Vertical Scale and the Vertical Position knobs of Channel 1 are used to set the horizontal scale and position.
- The Vertical Scale and the Vertical Position knobs of Channel 2 are used to set the vertical scale and position continuously.

The following functions can not work in the XY Format: Cursor

- | | |
|-------|---|
| Steps | <ol style="list-style-type: none">1. Push the Acquire button to show the right menu.2. Select XY Mode as ON or OFF in the right menu. |
|-------|---|
-

Counter

It is a 6-digit single-channel counter. The counter can only measure the frequency of the triggering channel. The frequency range is from 2 Hz to the full bandwidth. Only if the measured channel is in **Edge** mode of **Single** trigger type, the counter can be enabled. The counter is displayed at the bottom of the screen.



- Steps
1. Push Trigger Menu button, set the trigger type to Single, set the trigger mode to Edge, select the signal source.
 2. Push the Acquire button to show the right menu.
 3. Select **Counter** as **ON** or **OFF** in the right menu.

To Save and Recall a Waveform

Push the Utility button, select Function in the right menu, select Save in the left menu. By selecting Type in the right menu, you can save the waveforms, configures or screen images.

When the Type is selected as Wave, the menu is shown as the following table:

| Function Menu | Setting | Description |
|---------------|---------------------------|---|
| Function | Save | Display the save function menu. |
| Type | Wave | Choose the saving type as wave. |
| Source | CH1 CH2 Math All | Choose the waveform to be saved. (Choose All to save all the waveforms that are turned on. You can save into the current internal object address, or into USB storage as a single file.) |

| | | |
|-------------|----------------------|---|
| Object | ON OFF | The object Wave0 to Wave15 are listed in the left menu, turn the VARIABLE Knob to choose the object which the waveform is saved to or recall from. Recall or close the waveform stored in the current object address. When the show is ON, if the current object address has been used, the stored waveform will be shown, the address number and relevant information will be displayed at the top left of the screen; if the address is empty, it will prompt "None is saved". |
| Next Page | | Enter next page. |
| Close All | | Close all the waveforms stored in the object address. |
| File Format | BIN | For internal storage, only BIN can be selected. |
| | TXT | For external storage, the format can be BIN, TXT or CSV. |
| | CSV | |
| Storage | | Save the waveform of the source to the selected address. |
| Storage | Internal External | Save to internal storage or USB storage. |
| Prev Page | | Enter previous page |

When the Type is selected as Configure, the menu is shown as the following table:

| Function Menu | Setting | Description |
|---------------|-----------|--|
| Function | Save | Display the save function menu. |
| Type | Configure | Choose the saving type as configure. |
| Configure | Setting1 | The setting address. |
| | | |
| | Setting8 | |
| Save | | Save the current oscilloscope configure to the internal storage. |
| Load | | Recall configure from the selected address. |

When the Type is selected as Image, the menu is shown as the following table:

| Function Menu | Setting | Description |
|---------------|---------|--|
| Function | Save | Display the save function menu. |
| Type | Image | Choose the saving type as image. |
| Save | | Save the current display screen. The file can be only stored in a USB storage, so a USB storage must be connected first. The file is stored in BMP format. |

Save and Recall the Waveform

The oscilloscope can store 16 waveforms, which can be displayed with the current waveform at the same time. The stored waveform called out can not be adjusted.

In order to save the waveform of CH1, CH2 and Math into the object Wave0, the operation steps should be followed:

Steps

1. Turn on CH1, CH2 and Math channels.
2. Push the Utility button, select Function in the right menu, select Save in the left menu. In the right menu, select Type as Wave.
3. Saving: In the right menu, select Source as All.
4. In the right menu, press Object. Select Wave0 as object address in the left menu.
5. In the right menu, press Next Page, and select Storage as Internal.
6. In the right menu, press Save to save the waveform.
7. Recalling: In the right menu, press Prev Page, and press Object, select Wave0 in the left menu. In the right menu, select Object as ON, the waveform stored in the address will be shown, the address number and relevant information will be displayed at the top left of the screen.

Shortcut for Save function

The Copy button on the bottom of the front panel is the shortcut for Save function in the Utility function menu. Pressing this button is equal to the Save option in the Save menu. The waveform, configure or the display screen could be saved according to the chosen type in the Save menu.

Save the current screen image

The screen image can only be stored in USB disk, so you should connect a USB disk with the instrument.

Steps

1. Install the USB disk: Insert the USB disk into the USB Host port. If an icon  appears on the top right of the screen, the USB disk is installed successfully. If the USB disk cannot be recognized, format the USB disk according to the methods "in USB disk Requirements" on Page 54.
 2. After the USB disk is installed, push the Utility button, select Function in the right menu, select Save in the left menu. In the right menu, select Type as Image.
 3. Select Save in the right menu.
-

USB disk Requirements

Support USB disk format: USB 2.0 or below, FAT16 or FAT32, allocation unit size no exceed 4 k, max capacity 64 G. If the USB disk doesn't work properly, format your USB disk and then try again. There are two methods in format the USB disk, first by using computer system to format, the other one is through formatting software to format. (8 G or above USB disk can only use the second method to format, that is through formatting software to format.)

Use system-provided function to format the USB disk

Steps

1. Connect the USB disk to the computer.
2. Right click Computer → Manage to enter Computer Management interface.
3. Click Disk Management menu, and information about the USB disk will display on the right side with red mark 1 and 2.

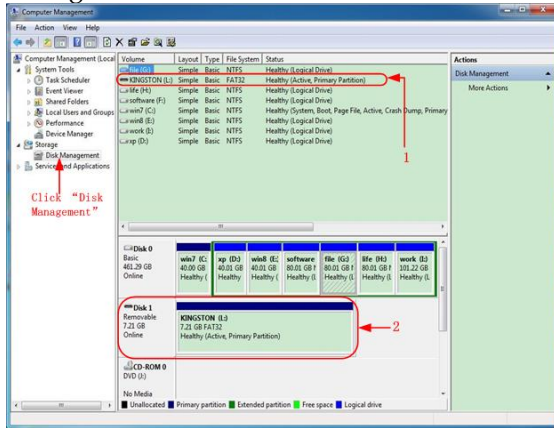

4. Right click 1 or 2 red mark area, choose Format. And system will pop up a warning message, click Yes.



5. Set File System as FAT32, Allocation unit size 4096. Check "Perform a quick format" to execute a quick format. Click OK, and then click Yes on the warning message.

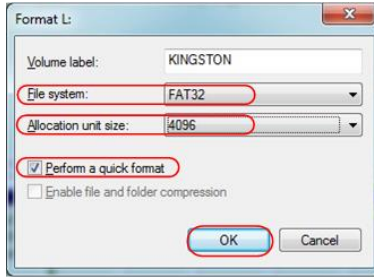

6. Formatting process.

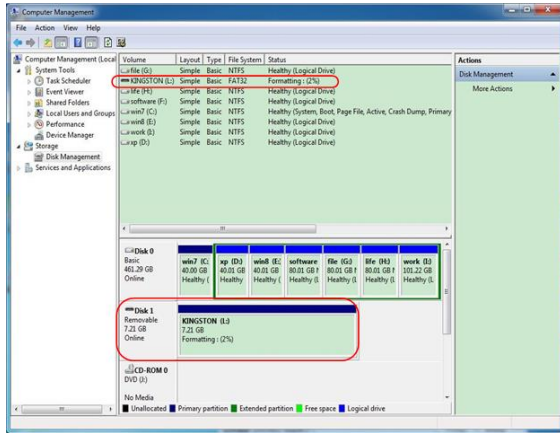

7. Check whether the USB disk is FAT32 with allocation unit size 4096 after formatting.

To Implement the Auxiliary System Function Setting

Configure

Push the Utility button, select Function in the right menu, select Configure in the left menu.



The description of Configure Menu is shown as the follows:

| Function Menu | Setting | Description |
|---------------|-----------|---|
| Function | Configure | Show the configure menu. |
| Language | | Select demand language. |
| KeyLock | | Lock all keys. Unlock method: push Trigger Menu button in trigger control area, then push Force button, repeat 3 times. |
| Device | PC | For calibration process, inspection, and parameter backup. |
| | USBTMC | Select device connected type. |
| | U disk | Used for USB device storage/upgrade. |
| About | | Show the version and serial number |

Display

Push the Utility button, select Function in the right menu, select Display in the left menu.

The description of Display Menu is shown as the follows:

| Function Menu | Setting | Description |
|---------------|---|---|
| Function | Display | Show the display menu. |
| BackLight | 0 % to 100 % | Turn the VARIABLE Knob to adjust the backlight. |
| Graticule |  | Select the grid type. |
| |  | |

| | | |
|-----------|---|---|
| |  | |
| Type | Dots Vect | Only the sample points are shown; Vector filling displays the space between adjacent sampling points in the middle. |
| Menu Time | OFF, 5 s to 30 s | Turn the VARIABLE Knob to set the disappear time of menu. |

Adjust

Push the Utility button, select Function in the right menu, select Adjust in the left menu.

The description of Adjust Menu is shown as the follows:

| Function Menu | Description |
|-----------------|---|
| Function Adjust | Bring up the calibration function menu. |
| Self Cal | Carry out the self-calibration procedure. |
| Default | Call out the factory settings. |
| ProbeCh. | Check whether probe compensation is good. |

Do Self Cal (Self-Calibration)

The self-calibration procedure can improve the accuracy of the oscilloscope under the ambient temperature to the greatest extent. If the change of the ambient temperature is up to or exceeds 5 °C, the self-calibration procedure should be executed to obtain the highest level of accuracy.

Before executing the self-calibration procedure, disconnect all probes or wires from the input connector. Push the Utility button, select Function in the right menu, the function menu will display at the left, select Adjust. If everything is ready, select Self Cal in the right menu to enter the self-calibration procedure of the instrument.

Probe checking

To check whether probe compensation is good. The results contain three circumstances: Overflow compensation, Good compensation, Inadequate compensation.

The probe inspection judgment is explained as follows.

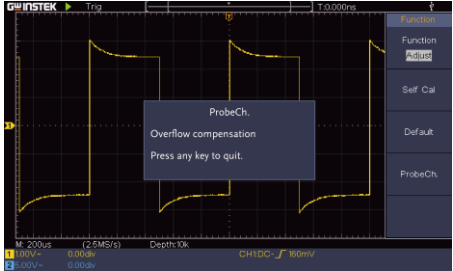
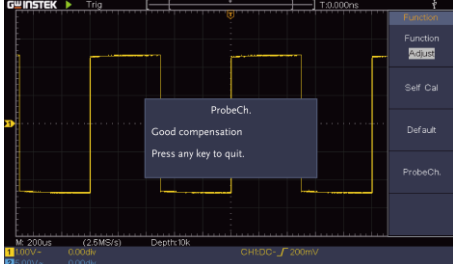
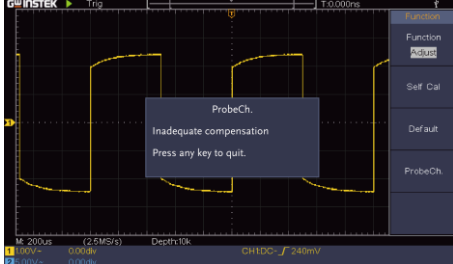
| Inspection Result | Screen Description |
|--------------------------------|--|
| <p>Overflow compensation</p> |  <p>The screenshot shows a square wave signal on a grid. A central dialog box displays the text: "ProbeCh. Overflow compensation Press any key to quit." The right side of the screen has a vertical menu with options: Function, Adjust, Self Cal, Default, and ProbeCh. The bottom status bar shows: "M: 200us (2.5MS/s) Depth: 1k CH1DC-/ 100mV".</p> |
| <p>Good compensation</p> |  <p>The screenshot shows a square wave signal on a grid. A central dialog box displays the text: "ProbeCh. Good compensation Press any key to quit." The right side of the screen has a vertical menu with options: Function, Adjust, Self Cal, Default, and ProbeCh. The bottom status bar shows: "M: 200us (2.5MS/s) Depth: 1k CH1DC-/ 200mV".</p> |
| <p>Inadequate compensation</p> |  <p>The screenshot shows a square wave signal on a grid. A central dialog box displays the text: "ProbeCh. Inadequate compensation Press any key to quit." The right side of the screen has a vertical menu with options: Function, Adjust, Self Cal, Default, and ProbeCh. The bottom status bar shows: "M: 200us (2.5MS/s) Depth: 1k CH1DC-/ 240mV".</p> |

According to the checking result, users can adjust probe attenuation to the best. Operation steps are as follows:

| | |
|-------|--|
| Steps | <ol style="list-style-type: none">1. Connect the probe to CH1, adjust the probe attenuation to the maximum.2. Push the Utility button, select Function in the right menu, select Adjust in the left menu.3. Select ProbeCh. in the right menu, tips about probe checking shows on the screen.4. Select ProbeCh. again to begin probe checking and the checking result will occur after 3 s; push any other key to quit. |
|-------|--|

Save

You can save the waveforms, configures or screen images.

Update

Use the front-panel USB port to update your instrument firmware using a USB memory device.

To Update your Instrument Firmware

Use the front-panel USB port to update your instrument firmware using a USB memory device.

USB memory device requirements

Insert a USB memory device into the USB port on the front panel. If the icon  appears on the top right of the screen, the USB memory device is installed successfully. If the USB memory device cannot be detected, format the USB memory device according to the methods “USB disk Requirements” on Page 54

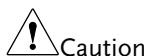

Updating your instrument firmware is a sensitive operation, to prevent damage to the instrument, do not power off the instrument or remove the USB memory device during the update process.

To update your instrument firmware, do the following:

- | | |
|-------|--|
| Steps | <ol style="list-style-type: none">1. Push the Utility button, select Function in the right menu, select Configure in the left menu, select About in the right menu. View the model and the currently installed firmware version.2. From a PC, visit our website and check if the website offers a newer firmware version. Download the firmware file. The file name must be Scope.update. Copy the firmware file onto the root directory of your USB memory device.3. Insert the USB memory device into the front-panel USB port on your instrument.4. Push the Utility button, select Function in the right menu, select Update in the left menu.5. In the right menu, select Start, the messages below will be shown. |
|-------|--|

```
The root directory of the udisk
must contain Socpe.update.
Do not power off the instrument.
The internal data will be cleared.
Press <start> to execute.
Press any key to quit.
```

- In the right menu, select Start again, the interfaces below will be displayed in sequence. The update process will take up to three minutes. After completion, the instrument will be shut down automatically.

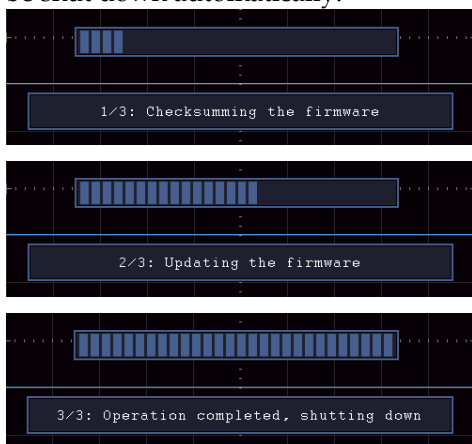

- Press the  button to power on the instrument.

To Measure Automatically

Push the Measure button to display the menu for the settings of the Automatic Measurements. At most 8 types of measurements could be displayed on the bottom left of the screen.

The oscilloscopes provide 30 parameters for auto measurement, including Period, Frequency, Mean, PK-PK, RMS, Max, Min, Top, Base, Amplitude, Overshoot, Preshoot, Rise Time, Fall Time, +PulseWidth, -PulseWidth, +Duty Cycle, -Duty Cycle, Delay A→B $\overleftrightarrow{A \rightarrow B}$, Delay A→B $\overleftrightarrow{A \rightarrow B}$, Cycle RMS, Cursor RMS, Screen Duty, Phase, +PulseCount, -PulseCount, RiseEdgeCnt, FallEdgeCnt, Area, and Cycle Area.

The “Automatic Measurements” menu is described as the following table:

| Function Menu | Setting | Description |
|---------------|-----------------------|--|
| Add CH1 | Meas Type (left menu) | Press to show the left menu, turn the VARIABLE Knob to select the measure type, press AddCH1 again to add the selected measure type of CH1. |
| Add CH2 | Meas Type (left menu) | Press to show the left menu, turn the VARIABLE Knob to select the measure type, press AddCH2 again to add the selected measure type of CH2. |
| Show | OFF | Hide the window of measures. |
| | CH1 | Show all the measures of CH1 on the screen. |
| Show | CH2 | Show all the measures of CH2 on the screen. |
| | Meas Type (left menu) | Press to show the left menu, turn the VARIABLE Knob to select the type need to be deleted, press Remove again to remove the selected measure type. |
| Remove All | | Remove all the measures. |

Measure

Only if the waveform channel is in the ON state, the measurement can be performed. The automatic measurement can not be performed in the following situation:

- On the saved waveform.
- On the Dual Wfm Math waveform.
- On the Video trigger mode.

On the Scan format, period and frequency can not be measured.

Measure the period, the frequency of the CH1, following the steps below:

- | Steps | |
|-------|---|
| | 1. Push the Measure button to show the right menu. |
| | 2. Select Add CH1 in the right menu. |
| | 3. In the left Type menu, turn the VARIABLE Knob to select Period. |
| | 4. In the right menu, select Add CH1. The period type is added. |
| | 5. In the left Type menu, turn the VARIABLE Knob to select Frequency. |
| | 6. In the right menu, select Add CH1. The frequency type is added. The measured value will be displayed at the bottom left of the screen automatically (see the figure below) |
-

Automatic measurement

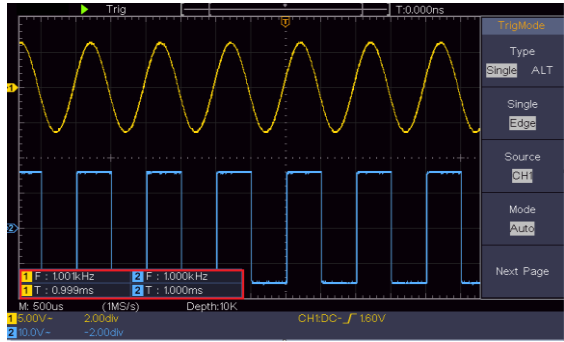

The automatic measurement of voltage parameters

The oscilloscopes provide automatic voltage measurements including Mean, PK-PK, RMS, Max, Min, Vtop, Vbase, Vamp, OverShoot, PreShoot, Cycle RMS, and Cursor RMS. The figure below shows a pulse with some of the voltage measurement points.

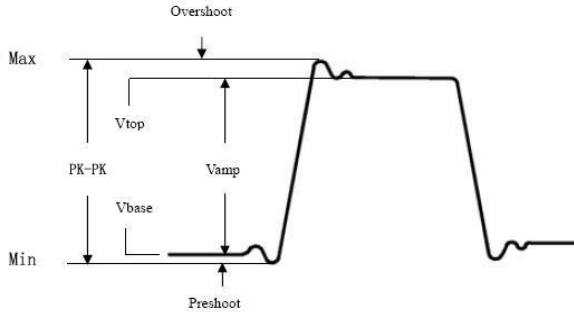

| | |
|-------|--|
| Mean | The arithmetic mean over the entire waveform. |
| PK-PK | Peak-to-Peak Voltage. |
| RMS | The true Root Mean Square voltage over the entire waveform. |
| Max | The maximum amplitude. The most positive peak voltage measured over the entire waveform. |
| Min | The minimum amplitude. The most negative peak voltage measured over the entire waveform. |
| Top | Voltage of the waveform's flat top, useful for square/pulse waveforms. |

| | |
|------------|--|
| Base | Voltage of the waveform's flat base, useful for square/pulse waveforms. |
| Amplitude | Voltage between Vtop and Vbase of a waveform. |
| Overshoot | Defined as $(V_{max}-V_{top})/V_{amp}$, useful for square and pulse waveforms. |
| Preshoot | Defined as $(V_{min}-V_{base})/V_{amp}$, useful for square and pulse waveforms. |
| Cycle RMS | The true Root Mean Square voltage over the first entire period of the waveform. |
| Cursor RMS | The true Root Mean Square voltage over the range of two cursors. |



The automatic measurement of time parameters

The oscilloscopes provide time parameters auto-measurements include Period, Frequency, Rise Time, Fall Time, +D width, -D width, +Duty, -Duty, Delay A→B ⏏ , Delay A→B ⏏ , and Duty cycle.

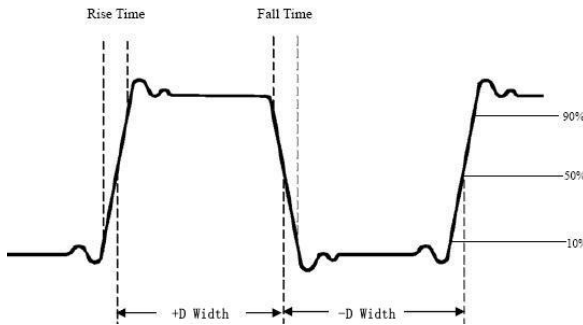



A pulse with some of the time measurement points



| | |
|-------------|---|
| Rise Time | Time that the leading edge of the first pulse in the waveform takes to rise from 10 % to 90 % of its amplitude. |
| Fall Time | Time that the falling edge of the first pulse in the waveform takes to fall from 90 % to 10 % of its amplitude. |
| +PulseWidth | The width of the first positive pulse in 50 % amplitude points. |

| | |
|---|---|
| -PulseWidth | The width of the first negative pulse in the 50 % amplitude points. |
| +Duty Cycle | +Duty Cycle, defined as +Width/Period. |
| -Duty Cycle | -Duty Cycle, defined as -Width/Period. |
| Delay A→B  | The delay between the two channels at the rising edge. |
| Delay A→B  | The delay between the two channels at the falling edge. |
| Screen Duty | Defines as (the width of the positive pulse)/(Entire period) |
| Phase | Compare the rising edge of CH1 and CH2, calculate phase difference of two channels. Phase difference = (Delay between channels at the rising edge+Period) × 360 °. |

Other measurements

| | |
|---|---|
| +PulseCount  | The number of positive pulses that rise above the mid reference crossing in the waveform. |
| -PulseCount  | The number of negative pulses that fall below the mid reference crossing in the waveform. |
| RiseEdgeCnt  | The number of positive transitions from the low reference value to the high reference value in the waveform. |
| FallEdgeCnt  | The number of negative transitions from the high reference value to the low reference value in the waveform. |
| Area  | The area of the whole waveform within the screen and the unit is voltage-second. The area measured above the zero reference (namely the vertical offset) is positive; the area measured below the zero reference is negative. The area measured is the algebraic sum of the area of the whole waveform within the screen. |

Cycle Area 

The area of the first period of waveform on the screen and the unit is voltage-second. The area above the zero reference (namely the vertical offset) is positive and the area below the zero reference is negative. The area measured is the algebraic sum of the area of the whole period waveform.



When the waveform on the screen is less than a period, the period area measured is 0.

To Measure with Cursors

Push the Cursor button to turn cursors on and display the cursor menu. Push it again to turn cursors off.

The Cursor Measurement for normal mode

The description of the cursor menu is shown as the following table:

| Function Menu | Setting | Description |
|----------------------------------|--------------|---|
| Type | Voltage | Display the voltage measurement cursor and menu. |
| | Time | Display the time measurement cursor and menu. |
| | Time&Voltage | Display the time and voltage measurement cursor and menu. |
| | AutoCursr | The horizontal cursors are set as the intersections of the vertical cursors and the waveform. |
| Line Type (Time&Voltage type) | Time | Makes the vertical cursors active. |
| | Voltage | Makes the horizontal cursors active. |
| Window (Wave zoom mode) | Main | Measure in the main window. |
| | Extension | Measure in the extension window. |
| Line | a | Turn the VARIABLE Knob to move line a. |
| | b | Turn the VARIABLE Knob to move line b. |
| | ab | Two cursors are linked. Turn the VARIABLE Knob to move the pair of cursors. |
| Source | CH1 | Display the channel to which the cursor measurement will be applied. |
| | CH2 | |

Perform the following operation steps for the time and voltage cursor measurement of the channel CH1:

- | | |
|-------|---|
| Steps | <ol style="list-style-type: none">1. Push Cursor to display the cursor menu.2. In the right menu, select Source as CH1.3. Press the first menu item in the right menu, select Time&Voltage for Type, two blue dotted lines displayed along the horizontal direction of the screen, two blue dotted lines displayed along the vertical direction of the screen. Cursor measure window at the left bottom of the screen shows the cursor readout.4. In the right menu, select Line Type as Time to make the vertical cursors active. If the Line in the right menu is select as a, turn the VARIABLE Knob to move line a to the right or left. If b is selected, turn the VARIABLE Knob to move line b.5. In the right menu, select Line Type as Voltage to make the horizontal cursors active. Select Line in the right menu as a or b, turn the VARIABLE Knob to move it.6. Push the horizontal ZOOM button to enter wave zoom mode. Push Cursor to show the right menu, select Window as Main or Extension to make the cursors shown in the main window or zoom window. |
|-------|---|
-

Time&Voltage
Cursor
Measurement

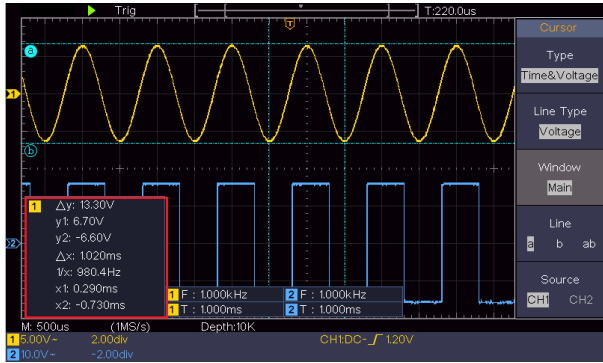

Auto Cursor

For the AutoCursr type, the horizontal cursors are set as the intersections of the vertical cursors and the waveform.

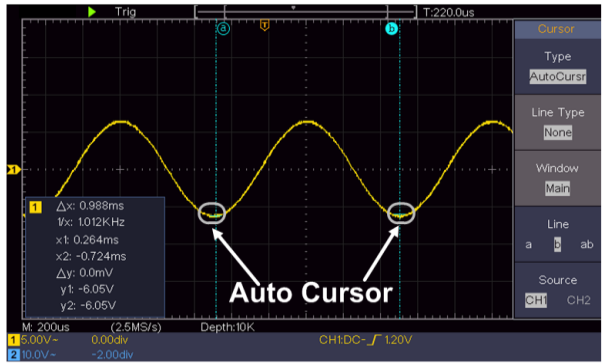

The Cursor Measurement for FFT mode

In FFT mode, push the Cursor button to turn cursors on and display the cursor menu.

The description of the cursor menu in FFT mode is shown as the following table:

| Function Menu | Setting | Description |
|----------------------------|-------------------|--|
| Type | Vamp | Display the Vamp measurement cursor and menu. |
| | Freq | Display the Freq measurement cursor and menu. |
| | Freq&Vamp | Display the Freq and Vamp measurement cursor and menu. |
| | AutoCursr | The horizontal cursors are set as the intersections of the vertical cursors and the waveform |
| Line Type (Freq&Vamp type) | Freq Vamp | Makes the vertical cursors active. Makes the horizontal cursors active. |
| Window (Wave zoom mode) | Main Extension | Measure in the main window. Measure in the FFT extension window. |
| Line | a | Turn the VARIABLE Knob to move line a. |
| | b | Turn the VARIABLE Knob to move line b. |
| | ab | Two cursors are linked. Turn the VARIABLE Knob to move the pair of cursors. |
| Source | Math FFT | Display the channel to which the cursor measurement will be applied. |

Perform the following operation steps for the amplitude and frequency cursor measurement of math FFT:

- | | |
|-------|---|
| Steps | <ol style="list-style-type: none">1. Press the Math button to display the right menu. Select Type as FFT.2. Push Cursor to display the cursor menu.3. In the right menu, select Window as Extension.4. Press the first menu item in the right menu, select Freq&Vamp for Type, two blue dotted lines displayed along the horizontal direction of the screen, two blue dotted lines displayed along the vertical direction of the screen. Cursor measure window at the left bottom of the screen shows the cursor readout.5. In the right menu, select Line Type as Freq to make the vertical cursors active. If the Line in the right menu is select as a, turn the VARIABLE Knob to move line a to the right or left. If b is selected, turn the VARIABLE Knob to move line b.6. In the right menu, select Line Type as Vamp to make the horizontal cursors active. Select Line in the right menu as a or b, turn the VARIABLE Knob to move it.7. In the right cursor menu, you can select Window as Main to make the cursors shown in the main window. |
|-------|---|
-

To Use Executive Buttons

Push the Cursor button to turn cursors on and display the cursor menu. Push it again to turn cursors off.

[Autoset] button

It's a very useful and quick way to apply a set of pre-set functions to the incoming signal, and display the best possible viewing waveform of the signal and also works out some measurements for user as well.

The details of functions applied to the signal when using Autoset are shown as the following table:

| Function Menu | Setting |
|-------------------|--------------------------------|
| Vertical Coupling | Current |
| Channel Coupling | Current |
| Vertical Scale | Adjust to the proper division. |
| Horizontal Level | Middle or ± 2 div |
| Horizontal Sale | Adjust to the proper division |
| Trigger Type | Slope or Video |
| Trigger Source | CH1 or CH2 |
| Trigger Coupling | DC |
| Trigger Slope | Current |
| Trigger Level | 3/5 of the waveform |
| Trigger Mode | Auto |
| Display Format | YT |
| Force | Stop |
| Inverted | Off |
| Zoom Mode | Exit |

Judge waveform type by Autoset

Five kinds of types: Sine, Square, video signal, DC level, Unknown signal.

The Menu is as below:

| Waveform | Menu |
|-----------------------------|--|
| Sine | Multi-period, Single-period, Cancel Autoset |
| Square | Multi-period, Single-period, Rising Edge, Falling Edge, Cancel Autoset |
| Video signal | Type (line, field), Odd, Even, Line NO., Cancel Autoset |
| DC level/ Unknown signal | Cancel Autoset |

Description of the right menu options

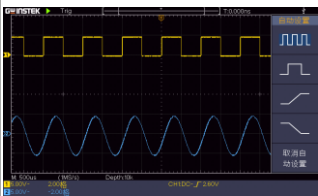
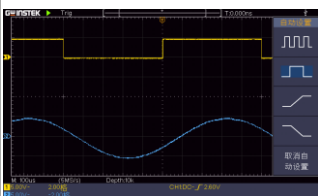
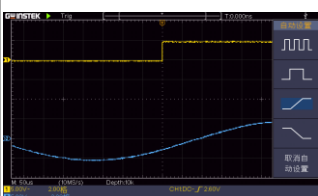
| Right menu options | Setting | Description |
|--------------------|---|--|
| Multi-period |  | To display multiple periods |
| Single-period |  | To display single period |
| Rising Edge |  | Display the rising edge of square waveform |

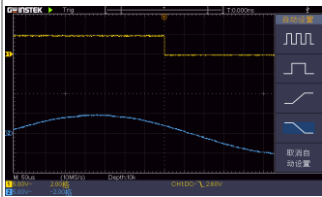
| | | |
|-----------------------|---|---|
| <p>Falling Edge</p> |  | <p>Display the rising edge of square waveform</p> |
| <p>Cancel Autoset</p> | | <p>Go back to display the upper menu and waveform information</p> |



Note

The Autoset function requires that the frequency of signal should be no lower than 20 Hz, and the amplitude should be no less than 5 mV. Otherwise, the Autoset function may be invalid.

[Run/Stop] button

Enable or disable sampling on input signals.



Note

When there is no sampling at STOP state, the vertical division and the horizontal time base of the waveform still can be adjusted within a certain range, in other words, the signal can be expanded in the horizontal or vertical direction.

When the horizontal time base is ≤ 50 ms, the horizontal time base can be expanded for 4 divisions downwards.

[Copy] button

This button is the shortcut for Save function in the Utility function menu. Pressing this button is equal to the Save option in the Save menu. The waveform, configure or the display screen could be saved according to the chosen type in the Save menu.

U**SE THE WAVEFORM GENERATOR (FOR GDS- 912G)**

The instrument can provide 4 basic waveforms, sine wave, square wave, ramp wave, pulse wave, and 16 arbitrary waveforms.

| | |
|-------------------------------------|----|
| Connect the output | 78 |
| Set the waveform | 78 |
| Output the sine waveform | 78 |
| Output the square waveform | 79 |
| Output the ramp waveform | 80 |
| Output the pulse waveform | 80 |
| Output the Arbitrary waveform | 82 |
| Built-in waveform list | 83 |
| Configure | 83 |

Connect the output

Connect the BNC cable to the port marked Output in the top of the oscilloscope.



Note

Do not input any electric such as signal, voltage or current into the Output port of the signal generator. To observe the output of the waveform generator, connect the other end of the BNC cable to the signal input connector of the oscilloscope.

Set the waveform

Steps

1. Press **AFG** button on the panel, and the screen will display the corresponding waveform setting menu.
2. Select the desired waveform in the right menu item, and the Settings menu for the corresponding waveform is displayed on the right.
3. Operate the Settings menu on the right side of the screen to set the parameters of the desired waveform.
4. Press **AFG** button on the panel, and the generator will output.

Output the sine waveform

The sine waveform setting menu includes: Freq/Period, Amplitude/High Level, Offset/Low Level.

Set the Frequency / Period

1. Press the **AFG Output** key to enter the sine waveform setting interface.
2. Press **Freq/Period** key, **Frequency** will display in the right menu (If there is no **Frequency** in the menu, select **Period** and press again to switch to **Frequency**), use the **VARIABLE**

Knob to set the desired value.

3. Press **Freq/Period** key again can switch to **Period** (If there is no **Period** in the menu, select **Frequency** and press again to switch to **Period**), use the **VARIABLE Knob** to set the desired value.
-

Set the Amplitude / High Level

1. Press the **AFG Output** key to enter the sine waveform setting interface.
 2. Press **Ampl/High Level** key, **Amplitude** will display in the right menu (If there is no **Amplitude** in the menu, select **High Level** and press again to switch to **Amplitude**), use the **VARIABLE Knob** to set the desired value.
 3. Press **Ampl/High Level** key again can switch to **High Level** (If there is no **High Level** in the menu, select **Amplitude** and press again to switch to **High Level**), use the **VARIABLE Knob** to set the desired value.
-

Set the Offset / Low Level

1. Press the **AFG Output** key to enter the sine waveform setting interface.
 2. Press **Offset/Low Level** key, **Offset** will display in the right menu (If there is no **Offset** in the menu, select **Low Level** and press again to switch to **Offset**), use the **VARIABLE Knob** to set the desired value.
 3. Press **Offset/Low Level** key again can switch to **Low Level** (If there is no **Low Level** in the menu, select **Offset** and press again to switch to **Low Level**), use the **VARIABLE Knob** to set the desired value.
-

Output the square waveform

The square waveform setting menu includes: Freq/Period, Amplitude/High Level, Offset/Low Level.

For the setting Freq/period, Amplitude/High level, Offset/Low level, please refer to the section "Output the sine waveform" on page 78.

Output the ramp waveform

The ramp waveform setting menu includes: Freq/Period, Amplitude/High Level, Offset/Low Level, Symmetry.

For the setting Freq/period, Amplitude/High level, Offset/Low level, please refer to the section "Output the sine waveform" on page 78.

| | |
|---------------------------------------|---|
| Set the symmetry of the ramp waveform | Press the right side of the ramp wave to set symmetry in the menu, use M keys to set the desired value. |
|---------------------------------------|---|

Output the pulse waveform

The pulse waveform setting menu includes: Freq/Period, Amplitude/High Level, Offset/Low Level, Pulse width/Duty, Rise Time/Fall Time.

For the setting Freq/period, Amplitude/High level, Offset/Low level, please refer to the section "Output the sine waveform" on page 78.

| | |
|--|--|
| Set the Pulse Width / Duty Cycle of the pulse waveform | <ol style="list-style-type: none"> 1. Press the AFG Output key to enter the pulse waveform setting interface. 2. Press the Next Page key to enter the next page menu. 3. Press Pulse Width/Duty key, Pulse Width will display in the right menu (If there is no Pulse Width in the menu, select Duty and press again to switch to Pulse Width), use the VARIABLE Knob to set the desired value. 4. Press Pulse Width/Duty key again can switch to Duty (If there is no Duty in the menu, select Pulse Width and press again to switch to Duty), use the VARIABLE Knob to set the |
|--|--|

desired value.

- Set the Rise time / Fall time of the pulse waveform
1. Press the **AFG Output** key to enter the pulse waveform setting interface.
 2. Press the **Next Page** key to enter the next page menu.
 3. Press **Rise Time/Fall Time** key, **Rise Time** will display in the right menu (If there is no **Rise Time** in the menu, select **Fall Time** and press again to switch to **Rise Time**), use the **VARIABLE Knob** to set the desired value.
 4. Press **Rise Time/Fall Time** key again can switch to **Fall Time** (If there is no **Fall Time** in the menu, select **Rise Time** and press again to switch to **Fall Time**), use the **VARIABLE Knob** to set the desired value.
-

Output the Arbitrary waveform

The arbitrary waveform setting menu includes: Freq/Period, Amplitude/High Level, Offset/Low Level, Common.

For the setting Freq/period, Amplitude/High level, Offset/Low level, please refer to the section "Output the sine waveform" on page 78.

- Type (built-in waveform)
- The system has 16 built-in waveforms. To select the built-in waveform:
1. Press the **AFG Output** key to enter the arbitrary waveform setting interface.
 2. Press the **Next Page** key to enter the next page menu.
 3. Press the **Common** key, the common waveform selection box will display, use the **VARIABLE Knob** to set the desired built-in waveforms and then press "Ok" to output built-in waveform.
-

Built-in waveform list

| Name | Explanation |
|-----------|--|
| AmpALT | Attenuation oscillation curve |
| AttALT | Gain oscillation curve |
| StairDn | Stair-down waveform |
| StairUD | Stair-up and stair-down waveform |
| StairUp | Stair-up waveform |
| Besselj | Besselj function |
| Bessely | Bessely function |
| Sinc | Sinc function |
| EXpFall | Exponential decline function |
| EXpRise | Exponential rise function |
| Gauss | Gaussian distribution, also known as the normal distribution |
| HaverSine | Semi-positive function |
| Log | Base 10 logarithmic function |
| Lorentz | Natural logarithmic waveform |
| Ln(X) | Natural logarithmic waveform |
| X^2 | Square function |

Configure

- Set the load
1. Press the **AFG Output** key to switch to configure setting interface.
 2. Press the **Load** key to set the instrument load to Hi-Z or 50 ohm.

D EMONSTRATION

Example 1: Measurement a Simple Signal

The purpose of this example is to display an unknown signal in the circuit, and measure the frequency and peak-to-peak voltage of the signal.

Rapid display of this signal

- | | |
|-------|---|
| Steps | <ol style="list-style-type: none">1. Set the probe menu attenuation coefficient as 10 X and that of the switch in the probe switch as 10 X.2. Connect the probe of Channel 1 to the measured point of the circuit.3. Push the Autoset button. The oscilloscope will implement the Autoset to make the waveform optimized, based on which, you can further regulate the vertical and horizontal divisions till the waveform meets your requirement. |
|-------|---|

Perform Automatic Measurement

The oscilloscope can measure most of the displayed signals automatically. To measure the period, the frequency of the CH1, following the steps below:

- | | |
|-------|--|
| Steps | <ol style="list-style-type: none">1. Push the Measure button to show the right menu.2. Select AddCH1 in the right menu.3. In the left Type menu, turn the VARIABLE |
|-------|--|

Knob to select Period.

4. In the right menu, select AddCH1. The period type is added.
5. In the left Type menu, turn the VARIABLE Knob to select Frequency.
6. In the right menu, select AddCH1. The frequency type is added. The measured value will be displayed at the bottom left of the screen automatically

Measure period and frequency value for a given signal

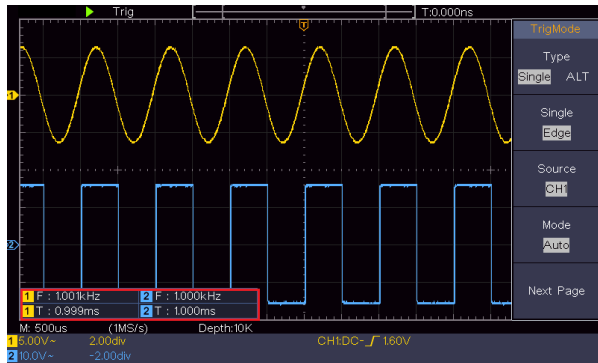

Example 2: Gain of a Amplifier in a Metering Circuit

The purpose of this example is to work out the Gain of an Amplifier in a Metering Circuit. First we use Oscilloscope to measure the amplitude of input signal and output signal from the circuit, then to work out the Gain by using given formulas.

Set the probe menu attenuation coefficient as 10 X and that of the switch in the probe as 10 X

Connect the oscilloscope CH1 channel with the circuit signal input end and the CH2 channel to the output end.

- | | |
|-------|--|
| Steps | <ol style="list-style-type: none">1. Push the Autoset button and the oscilloscope will automatically adjust the waveforms of the two channels into the proper display state.2. Push the Measure button to show the right menu.3. Select Add CH1 in the right menu.4. In the left Type menu, turn the VARIABLE Knob to select PK-PK.5. In the right menu, select Add CH1. The peak-to-peak type of CH1 is added.6. In the right menu, select Add CH2. The peak-to-peak type of CH2 is added.7. Read the peak-to-peak voltages of Channel 1 and Channel 2 from the bottom left of the screen (see next figure)8. Calculate the amplifier gain with the following formulas. Gain = Output Signal / Input signal Gain (db) = $20 \times \log(\text{gain})$ |
|-------|--|
-

Waveform of Gain Measurement

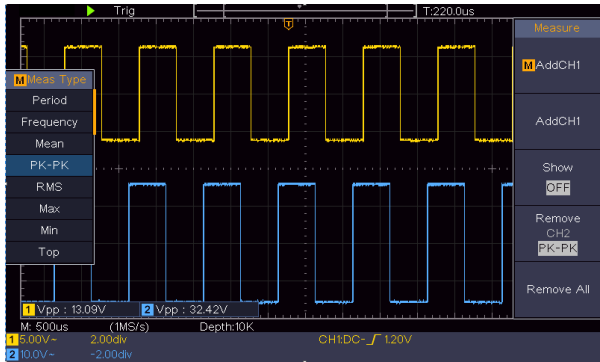

Example 3: Capturing a Single Signal

It's quite easy to use Digital Oscilloscope to capture non-periodic signal, such as a pulse and burr etc. But the common problem is how to set up a trigger if you have no knowledge of the signal? For example, if the pulse is the logic signal of a TTL level, the trigger level should be set to 2 volts and the trigger edge be set as the rising edge trigger. With various functions supported by our Oscilloscope, user can solve this problem by taking an easy approach. First to run your test using auto trigger to find out the closest trigger level and trigger type, this helps user to make few small adjustments to achieve a proper trigger level and mode. Here is how we achieve this. The operation steps are as follows:

-
- | | |
|-------|---|
| Steps | <ol style="list-style-type: none">1. Set the probe menu attenuation coefficient to 10 X and that of the switch in the probe to 10 X2. Adjust the Vertical Scale and Horizontal Scale knobs to set up a proper vertical and horizontal ranges for the signal to be observed.3. Push the Acquire button to display the right menu.4. In the right menu, select Acqu Mode as Peak Detect.5. Push the Trigger Menu button to display the right menu.6. In the right menu, select Type as Single.7. In the right menu, select Single as Edge.8. In the right menu, select Source as CH1.9. In the right menu, press Next Page, select Coupling as DC.10. In the right menu, select Slope as  (rising).11. Turn the Trigger Level knob and adjust the trigger level to the roughly 50 % of the signal to be measured. |
|-------|---|

12. Check the Trigger State Indicator on the top of the screen, if it is not Ready, push down the **Run/Stop** button and start acquiring, wait for trigger to happen. If a signal reaches to the set trigger level, one sampling will be made and then displayed in the screen. By using this approach, a random pulse can be captured easily. For instance, if we want to find a burst burr of high amplitude, set the trigger level to a slightly higher value of the average signal level, push the **Run/Stop** button and wait a trigger. Once there is a burr occurring, the instrument will trigger automatically and record the waveform during the period around the trigger time. By turning the **Horizontal Position** knob in the horizontal control area in the panel, you can change the horizontal triggering position to obtain the negative delay, making an easy observation of the waveform before the burr occurs (see next figure)

Capturing a Single Signal

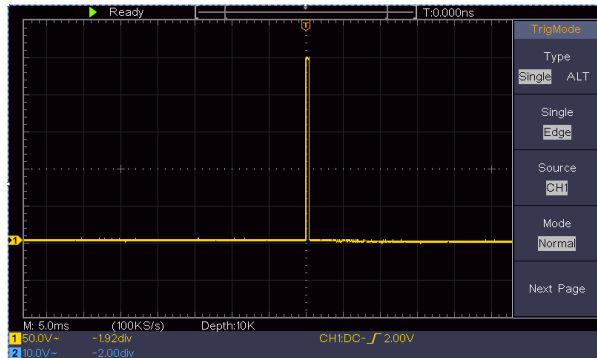

Example 4: Analyze the Details of a Signal

Noise Analysis

Noise is very common inside most of the electronic signal. To find out what's inside the noise and reduce the level of noise is very important function our oscilloscope is capable to offer. The level of noise sometime indicates a failure of electronic circuit. The Peak Detect functions acts an important role to help you to find out the details of these noise.

- Steps
1. Push the Acquire button to display the right menu.
 2. In the right menu, select Acqu Mode as Peak Detect.

The signal displayed on the screen containing some noise, by turning on Peak Detect function and changing time base to slow down the incoming signal, any peaks or burr would be detected by the function (see next figure)

Signal with
Noises

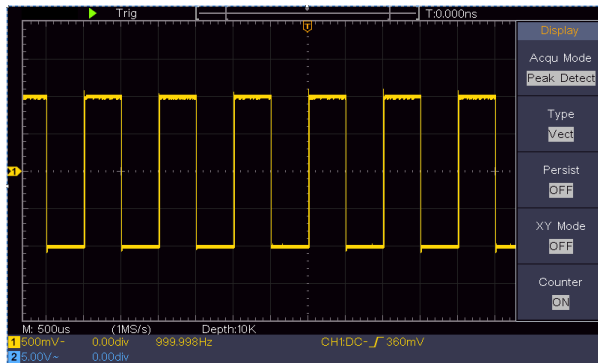

Separate Noises from the Signal

When focusing on signal itself, the important thing is to reduce the noise level as lower as possible, this would enable user to have more details about the signal. The Average function offered by our Oscilloscope can help you to achieve this. Here are the steps for how to enable Average function.

- Steps
1. Push the Acquire button to display the right menu.
 2. In the right menu, select Acqu Mode as Average.
 3. Turn the VARIABLE Knob and observe the waveform obtained from averaging the waveforms of different average number.

User would see a much reduced random noise level and make it easy to see more details of the signal itself. After applying Average, user can easily identify the burrs on the rising and falling edges of some part of the signal (see next figure)

Reduce Noise level by using Average function

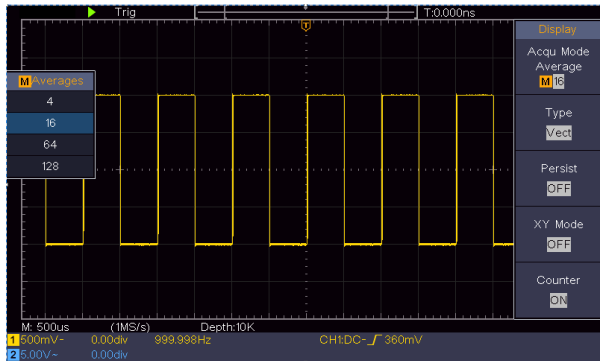

Example 5: Application of X-Y Function

Examine the Phase Difference between Signals of two Channels

Example: Test the phase change of the signal after it passes through a circuit network.

X-Y mode is a very useful when examining the Phase shift of two related signals. This example takes you step by step to check out the phase change of the signal after it passes a specified circuit. Input signal to the circuit and output signal from circuit are used as source signals.

For the examination of the input and output of the circuit in the form of X-Y coordinate graph, please operate according to the following steps:

- | Steps | |
|-------|--|
| | 1. Set the probe menu attenuation coefficient for 10 X and that of the switch in the probe for 10 X. |
| | 2. Connect the probe of channel 1 to the input of the network and that of Channel 2 to the output of the network. |
| | 3. Push the Autoset button, with the oscilloscope turning on the signals of the two channels and displaying them in the screen. |
| | 4. Turn the Vertical Scale knob, making the amplitudes of two signals equal in the rough. |
| | 5. Push the Acquire button to display the right menu. |
| | 6. In the right menu, select XY Mode as ON. The oscilloscope will display the input and terminal characteristics of the network in the Lissajous graph form. |
| | 7. Turn the Vertical Scale and Vertical Position knobs, optimizing the waveform. |

8. With the elliptical oscillogram method adopted, observe and calculate the phase difference (see next figure)

Lissajous Graph

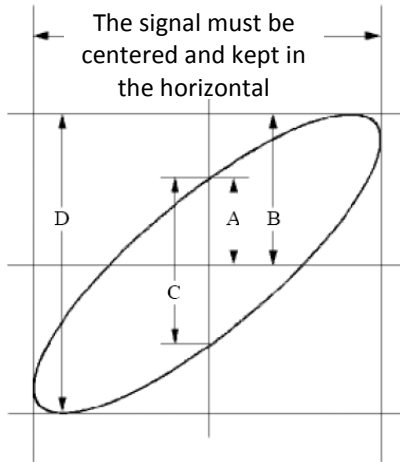

Based on the expression $\sin(q) = A/B$ or C/D , thereinto, q is the phase difference angle, and the definitions of A , B , C , and D are shown as the graph above. As a result, the phase difference angle can be obtained, namely, $q = \pm \arcsin(A/B)$ or $\pm \arcsin(C/D)$. If the principal axis of the ellipse is in the I and III quadrants, the determined phase difference angel should be in the I and IV quadrants, that is, in the range of $(0 \text{ to } \pi/2)$ or $(3\pi/2 \text{ to } 2\pi)$. If the principal axis of the ellipse is in the II and IV quadrants, the determined phase difference angle is in the II and III quadrants, that is, within the range of $(\pi/2 \text{ to } \pi)$ or $(\pi \text{ to } 3\pi/2)$.

Example 6: Video Signal Trigger

Observe the video circuit of a television, apply the video trigger and obtain the stable video output signal display.

Video Field Trigger

For the trigger in the video field, carry out operations according to the following steps:

- Steps
1. Push the **Trigger Menu** button to display the right menu.
 2. In the right menu, select **Type** as **Single**.
 3. In the right menu, select **Single** as **Video**.
 4. In the right menu, select **Source** as **CH1**.
 5. In the right menu, select **Modu** as **NTSC**.
 6. In the right menu, press **Next Page**, select **Sync** as **Field**.
 7. Turn the **Vertical Scale**, **Vertical Position** and **Horizontal Scale** knobs to obtain a proper waveform display (see next figure)

Waveform
Captured from
Video Field
Trigger

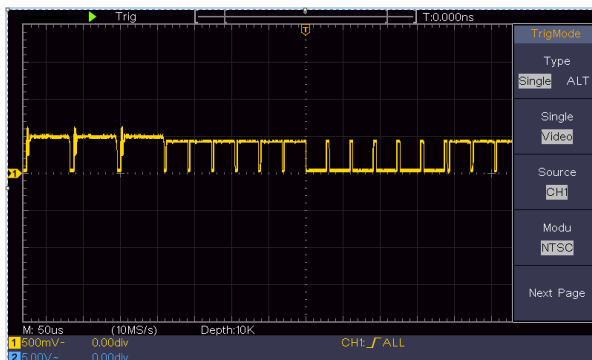

TROUBLESHOOTING

1. Oscilloscope is powered on but no Display.

- Check whether the power connection is connected properly.
 - Restart the instrument after completing the checks above.
 - If the problem persists, please contact us and we will be under your service.
-

2. After acquiring the signal, the waveform of the signal is not displayed in the screen.

- Check whether the probe is properly connected to the signal connecting wire.
 - Check whether the signal connecting wire is correctly connected to the BNC (namely, the channel connector).
 - Check whether the probe is properly connected with the object to be measured.
 - Check whether there is any signal generated from the object to be measured (the trouble can be shot by the connection of the channel from which there is a signal generated with the channel in fault).
 - Make the signal acquisition operation again.
-

3. The measured voltage amplitude value is 10 times or 1/10 of the actual value.

Look at the attenuation coefficient for the input channel and the attenuation ration of the probe, to make sure they are match (see the setion “How to Set the Probe Attenuation Coefficient” on page 21

4. There is a waveform displayed, but it is not stable.

- Check whether the Source item in the TRIG MODE menu is in conformity with the signal channel used in the practical application.
 - Check on the trigger Type item: The common signal chooses the Edge trigger mode for Type and the video signal the Video. If Alternate trigger is selected, both of the channel 1 and channel 2 trigger levels should be adjusted to the proper position. Only if a proper trigger mode is applied, the waveform can be displayed steadily.
-

5. No Display Responses to the Push-down of Run/Stop.

Check whether Normal or Signal is chosen for Polarity in the TRIG MODE menu and the trigger level exceeds the waveform range. If it is, make the trigger level is centered in the screen or set the trigger mode as Auto. In addition, with the Autoset button pressed, the setting above can be completed automatically.

6. The displaying of waveform seems getting slow after increasing AVERAGE value in Acqu Mode, or a longer duration is set in the Persist in Display.

It's normal as the Oscilloscope is working hard on many more data points.

SPECIFICATIONS

Unless otherwise specified, the technical specifications applied are for the oscilloscope only, and Probes attenuation set as 10 X. Only if the oscilloscope fulfills the following two conditions at first, these specification standards can be reached.

- This instrument should run for at least 30 minutes continuously under the specified operating temperature.
- If change of the operating temperature is up to or exceeds 5 °C, do a “Self-calibration” procedure (see the section “How to Implement Self-calibration” on page 25).

All specification standards can be fulfilled, except one(s) marked with the word “Typical”.

| Model | GDS-912 | GDS-912G |
|-------------------------|---|----------|
| Bandwidth | 100 MHz | 100 MHz |
| Channel | 2 | 2 |
| Bandwidth Limit | 20 MHz | 20 MHz |
| Calculated Rise Time | 3.5 ns | 3.5 ns |
| Vertical Sensitivity | | |
| Resolution | 8 bits: 2 mV/div to 10 V/div | |
| Input Coupling | AC, DC, GND | |
| Input Impedance | 1 M Ω ±2 %, in parallel with 12 pF±5 pF | |
| DC Gain Accuracy | ±3 % | |
| Polarity | Normal & Invert | |
| Maximum Input Voltage | 300 Vrms | |
| Offset Position Range | ±1 V (2 mV/div to 100 mV/div) ±60 V (200 mV/div to 10 V/div) | |
| Waveform Signal Process | +, -, ×, ÷, FFT | |

| | |
|--------------------------------|---|
| Trigger | |
| Source | CH1, CH2 |
| Trigger Mode | Auto, Normal, Single |
| Trigger Type | Edge, Video (NTSC, PAL, SECAM), ALT |
| Holdoff range | 100 ns to 10 s |
| Coupling | AC, DC |
| Sensitivity | 1 div |
| Horizontal | |
| Time base Range | 2 ns/div to 1000 s/div (1-2-5 increments) |
| Pre-trigger | Max. Record Length |
| Post-trigger | Record Length/2 |
| Time base Accuracy | ±100 ppm |
| Real Time Sample Rate | 1 GS/s (per-channel)* |
| Record Length | 20 Mpts / CH |
| Acquisition Mode | Normal, Peak detect, Average, Single |
| Peak Detection | 2.5 ns (typical) |
| Average | 4, 16, 64, 128 selectable |
| X-Y Mode | |
| X-Axis Input | CH1 |
| Y-Axis Input | CH2 |
| Phase Shift | ±3 degrees |
| Cursors and Measurement | |
| Cursors | ΔV and ΔT between cursors, auto cursor |
| Automatic Measurement | Period, Frequency, Mean, PK-PK, RMS, Max, Min, Top, Base, Amplitude, Overshoot, Preshoot, Rise Time, Fall Time, +PulseWidth, -PulseWidth, +Duty Cycle, -Duty Cycle, Delay A→B (Rising), Delay A→B (Falling), Cycle RMS, Cursor RMS, Screen Duty, Phase, +PulseCount, -PulseCount, RiseEdgeCnt, FallEdgeCnt, Area, and Cycle Area. |
| Control Panel Function | |
| Auto counter | available |
| Autoset | Single button, automatic setup of all channels for vertical, horizontal and trigger systems. With "Cancel Autoset" |
| Save Setup | 8 set |
| Save Waveform | 16 waveforms |

* At 1000-point record length

| | |
|--------------------|--|
| Display | |
| TFT LCD Type | 7" inch LCD |
| Display Resolution | 800 horizontal × 480 vertical pixels |
| Interpolation | sin(x)/x |
| Waveform Display | Dots, vectors, variable persistence (1 s, 2 s, 5 s), infinite persistence |
| Display Graticule | 8 x 15 divisions |
| Display mode | Y-T and X-Y |
| Interface | |
| USB | USB 2.0 Host/Device (Only one type is supported at a time, can't use both at the same time.) Host mode: Supporting Mass Storage Class(FAT16/32) Device mode: Supporting USBTMC Class |

| | |
|------------------------------------|--|
| AFG Specifications (GDS-912G Only) | |
| Channel | 1 |
| Sample Rate | 125 MSa/s |
| Vertical Resolution | 14 bit |
| Max. Frequency | 25 MHz |
| Standard Waveform | Sine wave, square wave, ramp wave, pulse wave, arbitrary wave |
| Built-in ARB Waveform | Sinc, exponential rise, exponential decline, Gaussian more than 16 kinds |
| Output Range | 0.05 V peak to peak to 3 V peak to peak (50 Ω) |
| Output Resolution | 1 mV |
| Output Accuracy | ± (1 % of setting + 1 mVpp) typical value; 1 kHz sine 0 V offset |
| Offset Range | ± (3 V - amplitude Vpp/2) |
| Offset Resolution | ± (1 % of setting + 1 mV + amplitude Vpp * 0.5 %) |
| Sine | |
| Frequency Range | 0.1 Hz to 25 MHz |
| Flatness | Relative to 100 kHz Sine wave, 1 Vpp, 50 Ω ≤ 10 MHz: ± 0.3 dB 10 MHz to 25 MHz: ± 0.5 dB |
| Harmonic Distortion | -35 dBc |
| Stray (Non-harmonic) | -40 dBc |

| | |
|---------------------------|--|
| Total Harmonic Distortion | 0.80 % |
| S/N Ratio | 50 dB |
| Square/Pulse | |
| Frequency Range | 0.1 Hz to 5 MHz |
| Rise/Fall time | Square < 30 ns; Pulse > 12 ns |
| Overshoot | <5 % |
| Duty cycle | Square: 50 % Pulse: 0.4 % to 99.6 % |
| Min. Pulse Width | 100 ns |
| Jitter | ±100 ppm |
| Ramp | |
| Frequency Range | 0.1 Hz to 1 MHz |
| Linearity | <2 % of peak output (typical 1 kHz, 1 V _{pp} , symmetry 50 %) |
| Symmetry | 0 % to 100 % |
| Miscellaneous | |
| Multi-language menu | available |
| Operation environment | Temperature: 0 °C to 40 °C. Relative Humidity ≤ 90 % |
| Power consumption | 16 Watts approx. |
| Dimensions | 301 mm × 152 mm × 70 mm |
| Weight | 1.1 kg |